

I-SPY



Photocopy
Masters
Book

1



Julie Ashworth and John Clark

Oxford University Press

Contents

- i-ii Teacher's Notes
- A Password Pictures (Introduction Unit)
- B Password Pictures (Units 1 and 2)
- C Password Pictures (Units 3 and 4)
- D Password Pictures (Units 5 and 6)
- E Password Pictures (Units 7 and 8)
- F Bingo Cover Cards
- G Classroom Playing Cards
- H Rubbish Puppets
- I Rubbish Puppets Theatre Backdrop
- J 'Where's my Bear?' Story Cards
- K 'Where's my Bear?' Story Cards
- L 'Billy and the Monster' Story Cards
- M 'Billy and the Monster' Story Cards
- N 'Billy and the Monster' Story Cards
- O Spy Game
- P Code Wheels
- Q Puzzle Cards (Unit 1)
- R Puzzle Cards (Unit 2)
- S Puzzle Cards (Unit 3)
- T Code Strips
- U Puzzle Cards (Unit 5)
- V Puzzle Cards (Unit 6)
- W Puzzle Cards (Unit 7)
- * 'Where's my Bear?' Story Flashcards
- * 'Billy and the Monster' Story Flashcards

* For use by teachers who do not have the full-colour Story Flashcards.



Photocopy Masters A–E

Passwords Poster and Password Pictures

The Password Pictures are for use with the full-size Passwords Poster to present the new password at the start of each lesson. Before each lesson, cut out the relevant picture (as directed in the Teacher's Book notes) and then stick it (using Blu-Tack) in the space provided on the poster. Photocopy Master A contains only two Password Pictures and a reproduction of the Passwords Poster. Make one copy of the poster picture for each pupil. (Pupils can stick this in the front of their Activity Book and keep a record of the passwords by colouring in each item in their picture as it is presented.) See Spy File B in the Teacher's Book for further ideas.

Photocopy Master F

Bingo Cover Cards

These word cards are for use with the Bingo games in Units 2, 5, and 6. The cards are used to cover the pictures during the game. Make one copy of Photocopy Master F for each pupil, and give them the appropriate section for each game.

Photocopy Master G

Classroom Playing Cards

These cards are for use in Unit 2, and suggested games are given in the Unit 2 lesson notes in the Teacher's Book. Make one copy of Photocopy Master G for each pupil.

Photocopy Masters H and I

Rubbish Puppets and Rubbish Puppets Theatre Backdrop

The Rubbish Puppets and the theatre backdrop form part of the project at the end of Unit 2. The Rubbish Puppets Theatre Backdrop is for use in recreating the Rubbish cartoon on page 17 of the Course Book. The puppets themselves can be used with any of the Rubbish cartoons for further practice or for pupils to create their own dialogues or role plays. Make one copy of each page for each pupil. Pupils colour in and cut out the puppets and theatre backdrop picture. Store the finished puppets in envelopes in the classroom and they can be used at any time.

Photocopy Masters J and K

'Where's my Bear?' Story Cards

These are reproductions of the Story Flashcards that are used in Unit 4. The Story Cards are used in games and optional activities. Make one copy of each page for each pupil.

Photocopy Masters L–N

'Billy and the Monster' Story Cards

These are reproductions of the Story Flashcards that are used in Unit 7. The Story Cards are used in games and optional activities. Make one copy of each page for each pupil.

Photocopy Master O

Spy Game

This can be used at any time after Unit 7 to provide practice of all the main question forms. Make one copy of Photocopy Master O for each pupil, and one extra copy. Cut out the cards on the extra copy. Ask for eight volunteers to stand at the front of the class. Give each volunteer a card. The class ask questions to fill in the grid and identify which spy is which.

When photocopying pages for use in games, it is preferable to copy directly onto thin card. If paper is used, the image is visible on the reverse side and this makes guessing games difficult to play. Some photocopiers can copy onto thin card; if this is not possible copy onto paper and stick onto dark card.





Photocopy Master P

Code Wheels

These are for use with the Puzzle Cards on Photocopy Masters Q-S, to provide extra vocabulary practice at the end of each of Units 1-3. (For instructions see the notes on Puzzle Cards below.) Each pupil needs one copy of Photocopy Master P and a paper fastener to fasten the wheels together. Keep the Code Wheels in the classroom for future use.

Photocopy Masters Q-S

Puzzle Cards

There are three sheets of Puzzle Cards, to be used with the Code Wheels in Units 1-3. There are four cards per sheet. There are two ways to use the cards depending upon your resources:

- 1 Copy one sheet per pupil and cut out the four cards. Give Puzzle Card 1 to each pupil. Pupils use their Code Wheels to work out the Code Words and write them on the Puzzle Card. Check each pupil's answers and then give them the next Puzzle Card.
- 2 Copy one sheet for every four pupils. Cut out the four Puzzle Cards and cover them with clear plastic if possible. Give one card to each pupil. Pupils use their Code Wheels to work out the Code Words and write them in their exercise books. Check each pupil's answers and then give them another Puzzle Card.

You can make further cards yourself, or pupils can make their own. The cards can be stored in the classroom to provide an invaluable resource which can be added to or used at any time.

How to work out the codes

Read the clue on each Puzzle Card (e.g. A=√ on Puzzle Card 1). Turn the small wheel until the √ symbol is alongside the letter A on the large wheel. Keep the wheels in this position. Find the letter for each symbol and write them on the Puzzle Card to work out the Code Words.

Photocopy Master T

Code Strips

These are for use with the Puzzle Cards on Photocopy Masters U-W, to provide extra vocabulary practice at the end of each of Units 5-7. Each pupil needs one copy of Photocopy Master T and glue to fasten strips A and B together. Keep the Code Strips in the classroom for future use.

Photocopy Masters U-W

Puzzle Cards

There are three sheets of Puzzle Cards, to be used with the Code Strips in Units 5-7. There are four cards per sheet. Prepare the cards as explained above for Photocopy Masters Q-S.

How to work out the codes

Read the clue on each Puzzle Card (e.g. A=10 on Puzzle Card 1). Place the number 10 (on strip C) under the letter A (on strip B). Keep the strips in this position. Find the letter above each number and write these letters to work out the Code Words.

Story Flashcards

These are for the use of teachers who do not have the printed colour flashcards, and need to make their own. The flashcards should be copied, cut out, coloured in, and stuck onto card. For 'Where's my Bear?' you should follow the colours of the items on page 27 of the Course Book. For 'Billy and the Monster' you should colour the monster's body parts according to the colour coding on the flashcards. The flashcard reproductions can also be used to make full-size class books: pupils colour the sheets, staple them together, and copy the text onto the blank pages.

Code Wheel Answers

PMQ	<i>Puzzle Card 1</i>	<i>Puzzle Card 2</i>
	1 a car	1 pink
	2 green	2 one
	3 a girl	3 a house
	4 two	4 a bed
	5 purple	5 eight
	6 five	6 red

<i>Puzzle Card 3</i>	<i>Puzzle Card 4</i>
1 four	1 blue
2 yellow	2 three
3 nine	3 a dog
4 a boy	4 orange
5 six	5 white
6 a cat	6 seven

PMR	<i>Puzzle Card 5</i>	<i>Puzzle Card 6</i>
	1 a book	1 the sun
	2 a pencil	2 a rubber
	3 a tree	3 a table
	4 a bag	4 one
	5 a kite	5 a pen
	6 eight	6 a bin

<i>Puzzle Card 7</i>	<i>Puzzle Card 8</i>
1 ten	1 a wall
2 the floor	2 a pencil sharpener
3 a bottle	3 the moon
4 a ball	4 a chair
5 a door	5 a ruler
6 white	

PMs	<i>Puzzle Card 9</i>	<i>Puzzle Card 10</i>
	1 eleven	1 brown
	2 a candle	2 a chair
	3 a snake	3 a birthday cake
	4 a rubber	4 a ball
	5 orange	5 blue
	6 a yo-yo	

<i>Puzzle Card 11</i>	<i>Puzzle Card 12</i>
1 a door	1 a pear
2 four	2 a present
3 a flower	3 black
4 a balloon	4 a kite
5 grey	5 nine
6 twelve	6 a baby

Code Strip Answers

PMU	<i>Puzzle Card 1</i>	<i>Puzzle Card 2</i>
	1 a lion	1 a bee
	2 an egg	2 kitchen
	3 living room	3 an elephant
	4 a pig	4 an umbrella
	5 bathroom	5 a sheep
	6 a horse	6 bedroom

<i>Puzzle Card 3</i>	<i>Puzzle Card 4</i>
1 a cow	1 a frog
2 a hat	2 dining room
3 a bird	3 an apple
4 an ice-cream	4 a rabbit
5 a toilet	5 a clock
6 an orange	6 a key

PMV	<i>Puzzle Card 5</i>	<i>Puzzle Card 6</i>
	1 chips	1 a zip
	2 a bike	2 a tomato
	3 a banana	3 a ghost
	4 a baby	4 chocolate
	5 a flag	5 a key
	6 a bear	6 an apple

<i>Puzzle Card 7</i>	<i>Puzzle Card 8</i>
1 a doll	1 cheese
2 a hamburger	2 a box
3 an umbrella	3 a plane
4 a fish	4 a robot
5 a star	5 a pizza
6 twelve	6 eleven

PMW	<i>Puzzle Card 9</i>	<i>Puzzle Card 10</i>
	1 a van	1 an eye
	2 a mouth	2 a queen
	3 a table	3 a tree
	4 a monster	4 hair
	5 chips	5 yellow
	6 a bike	6 cheese

<i>Puzzle Card 11</i>	<i>Puzzle Card 12</i>
1 a nose	1 an ear
2 five	2 a watch
3 a leaf	3 a robot
4 a coat	4 green
5 a ghost	5 a horse
6 a frog	6 jeans



3



4

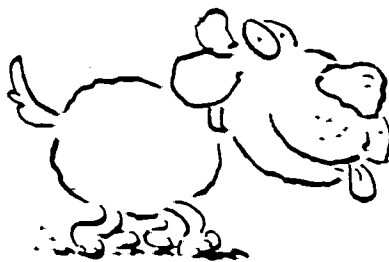

5

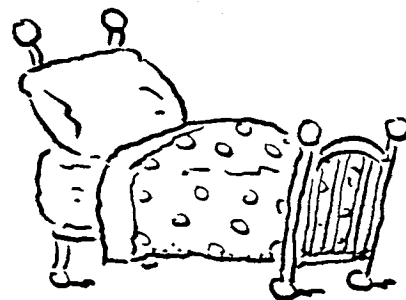

6

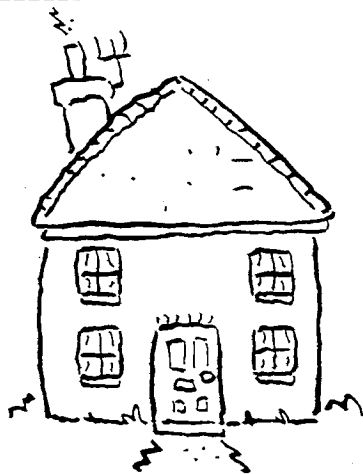

7

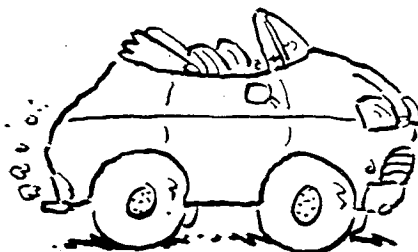

8



9



10

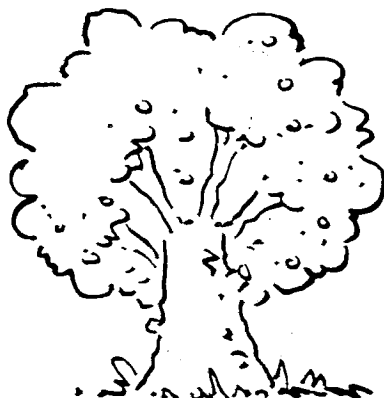

11

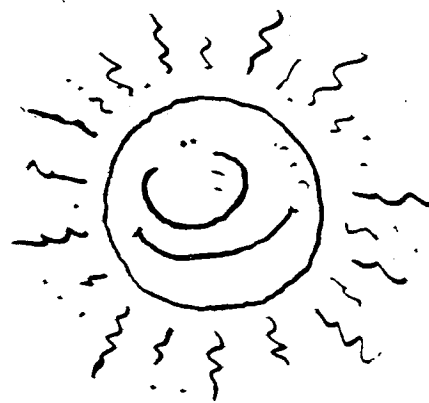

12

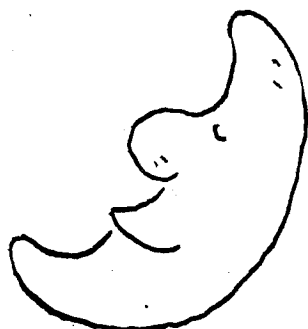

13

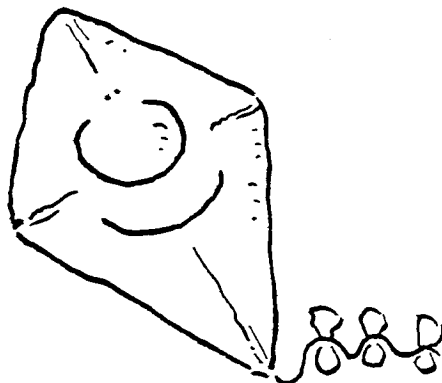

14

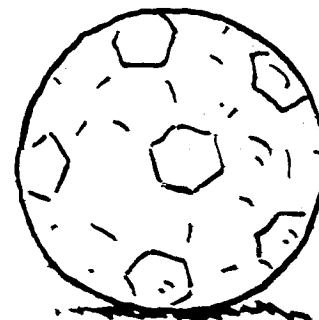

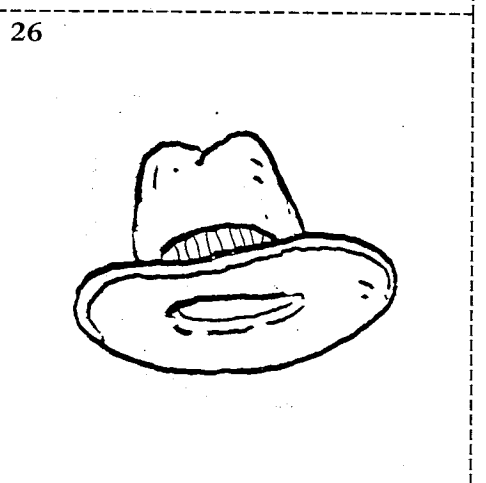
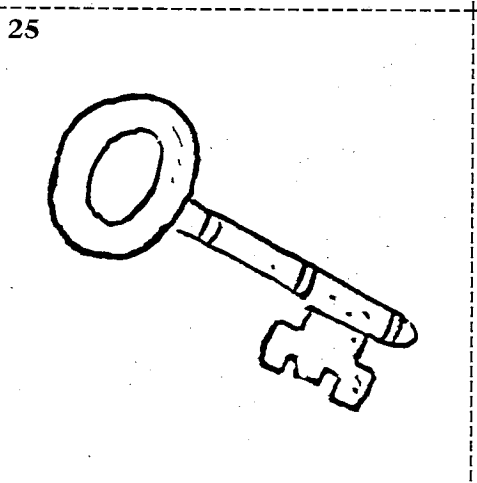
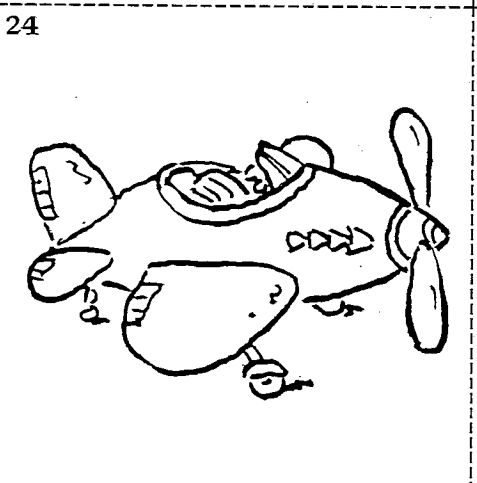
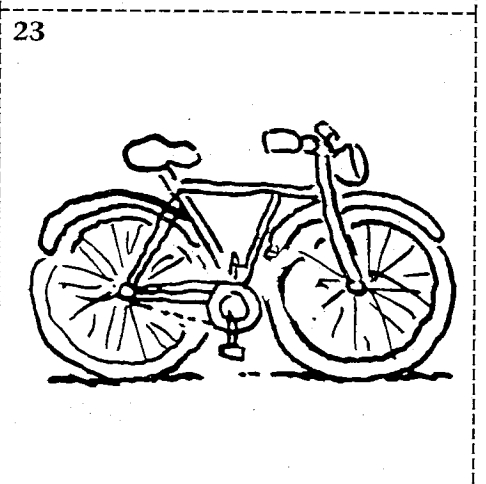
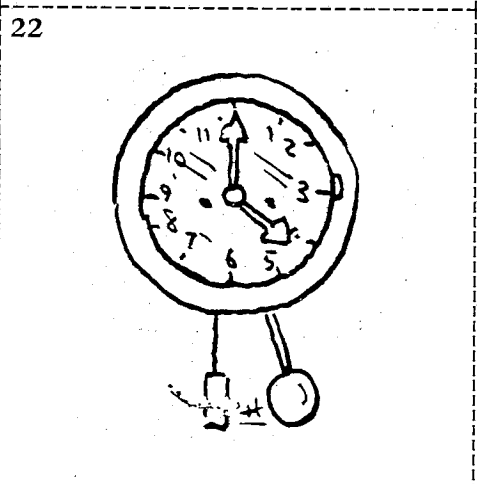
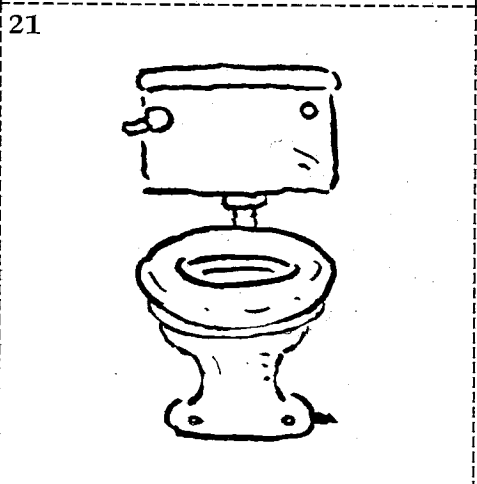
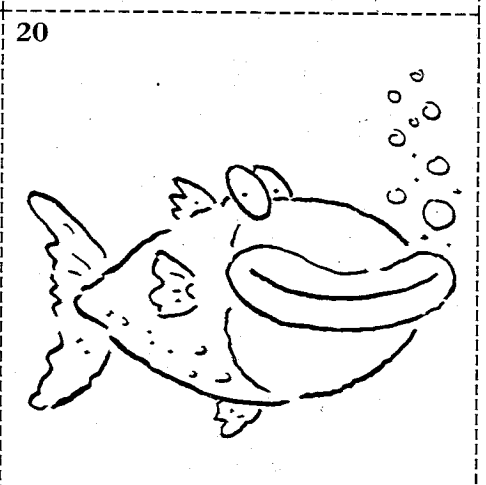
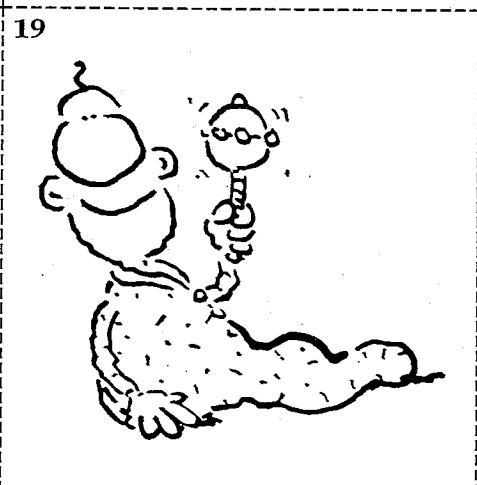
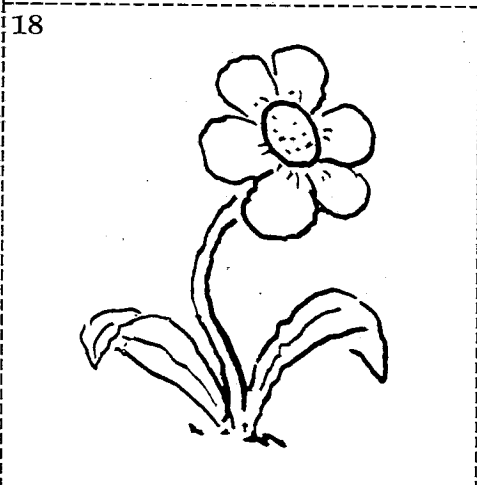
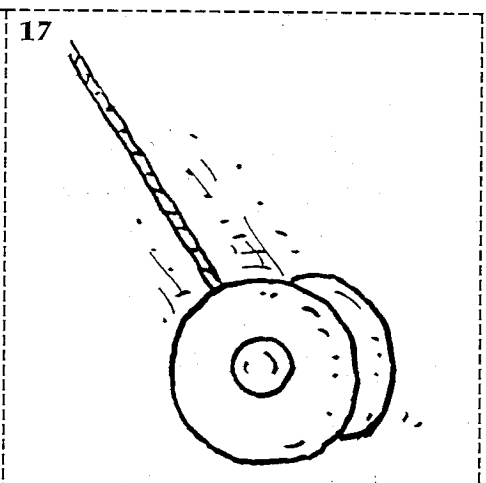
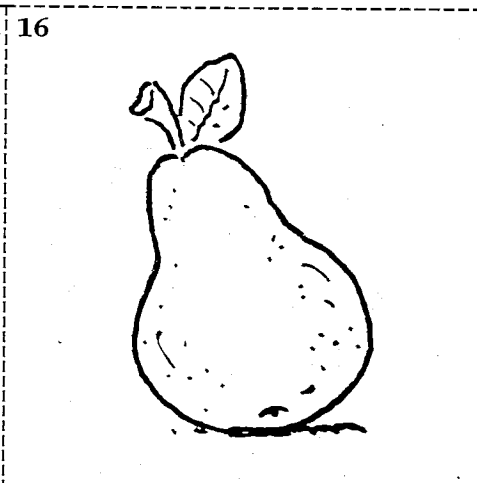
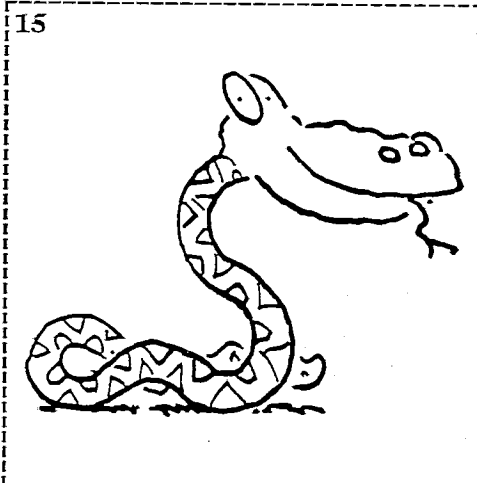



27

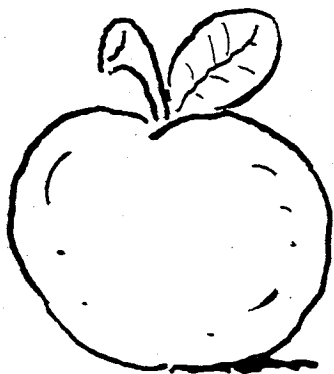

28

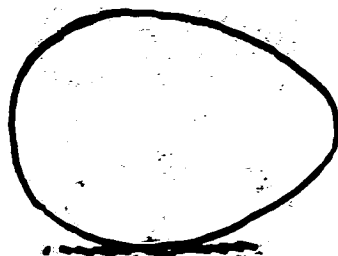

29

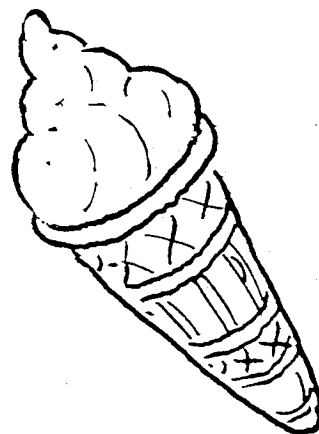

30

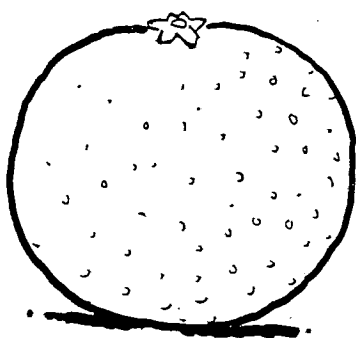

31



32

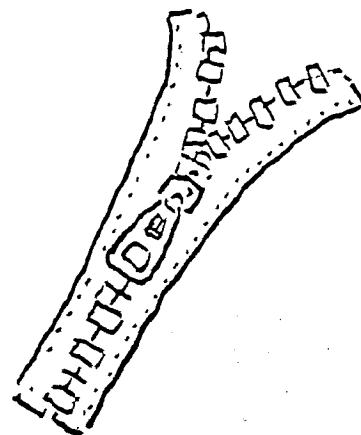

33

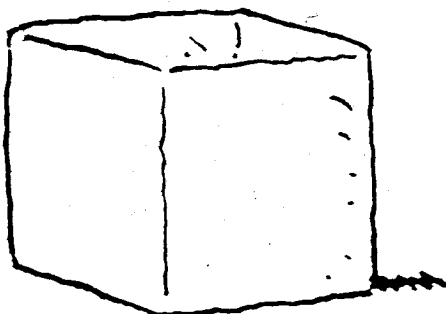

34



35

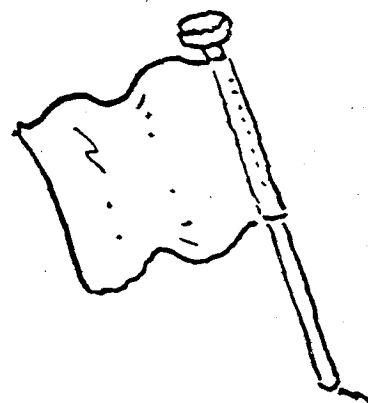

36

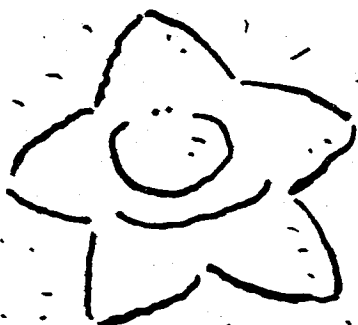

37

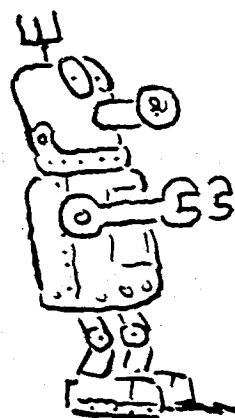

38





39

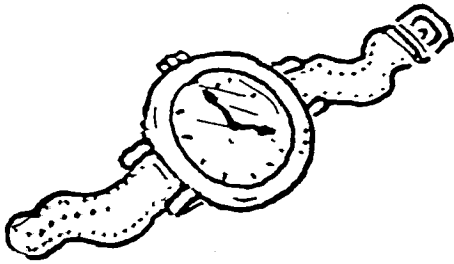

40



41



42

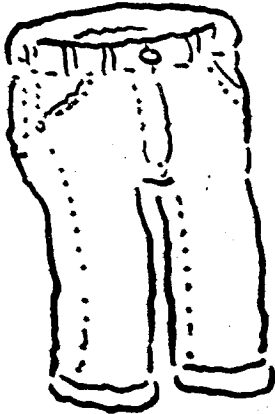

43

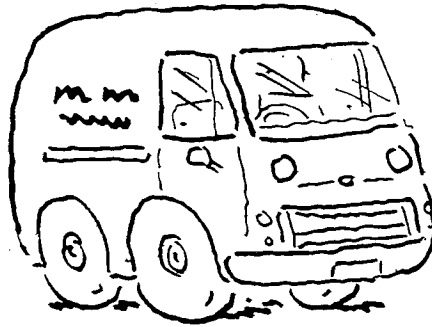

44

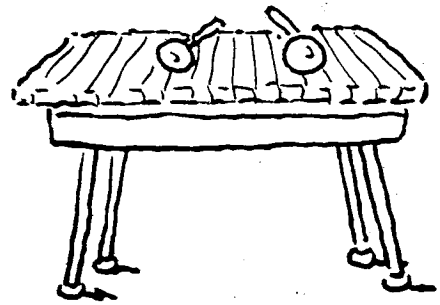

45

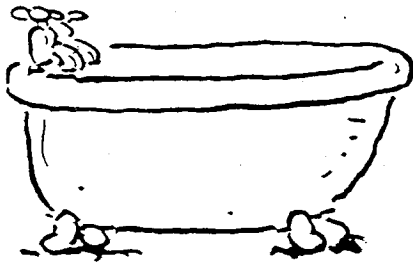

46



47

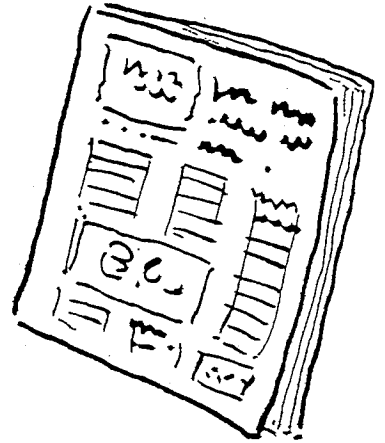

48

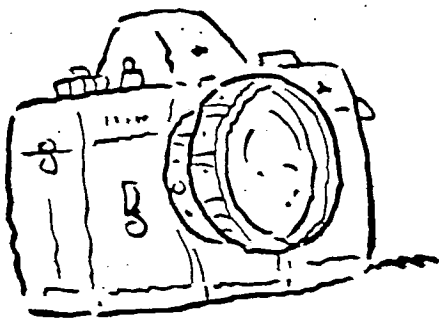

49

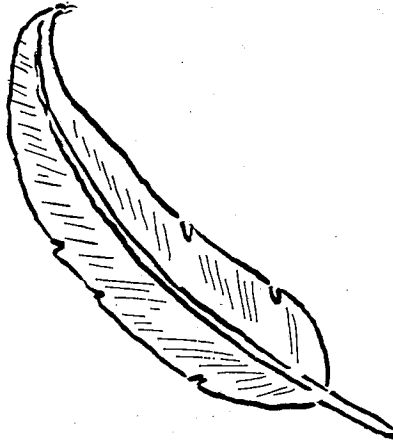

50

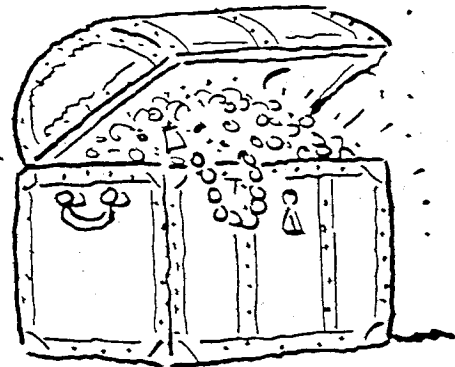



a book	a pencil	a rubber	a pencil sharpener
a bag	a ruler	a pencil case	a pen

Unit 2 Lesson 4 Classroom

an elephant	a frog	a horse	a bird
a cow	a snake	a lion	a rabbit

Unit 5 Lesson 4 Animals

an orange	an ice-cream	an egg	a tomato
chips	a hamburger	chocolate	an apple
a pear	a pizza	a banana	cheese

Unit 6 Lesson 3 Food

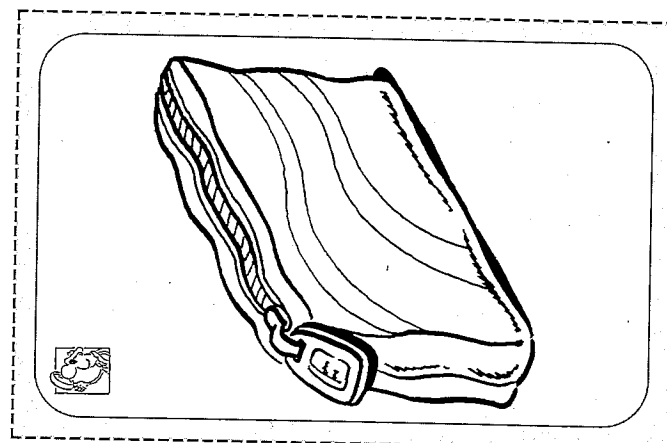
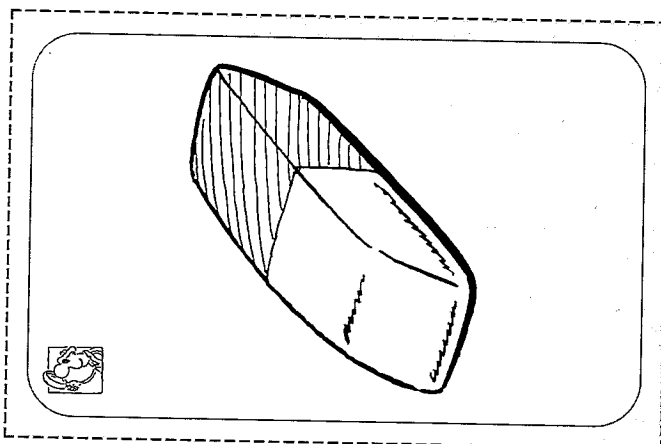
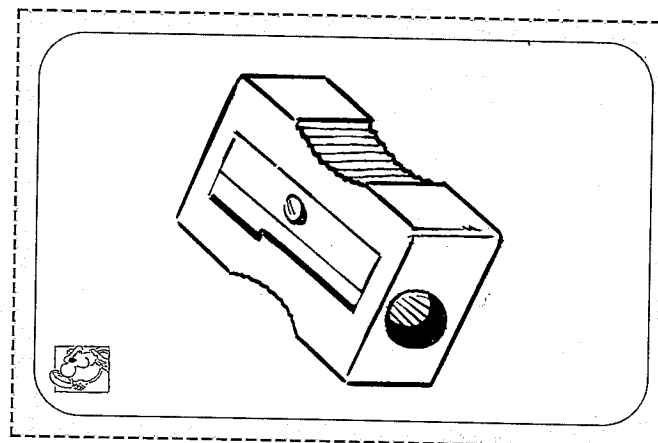
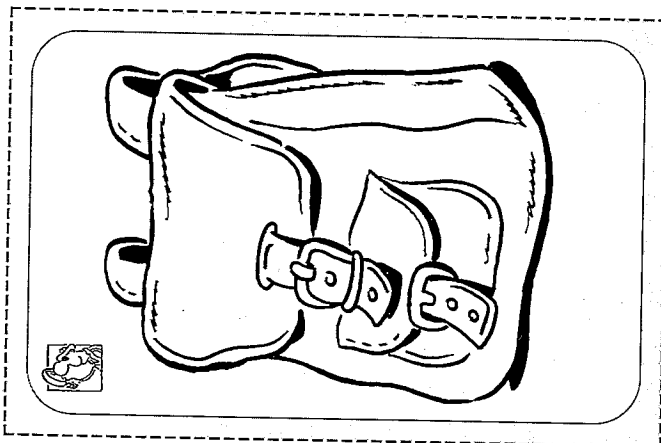
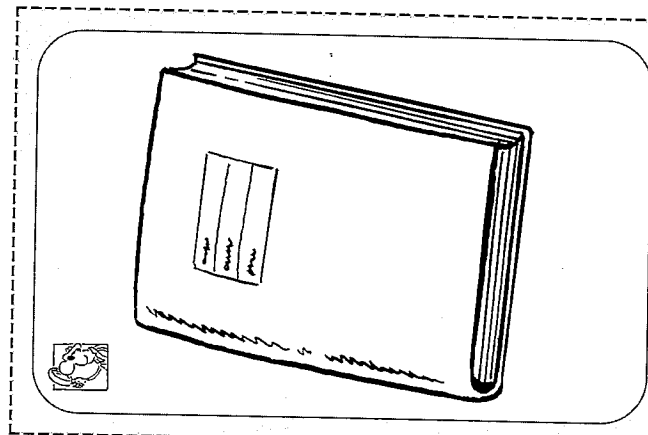
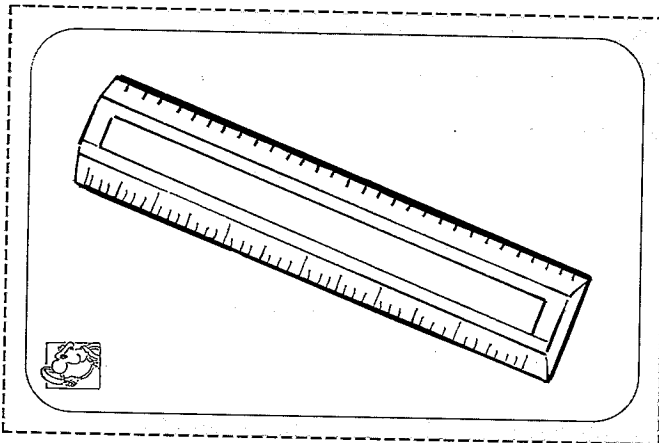
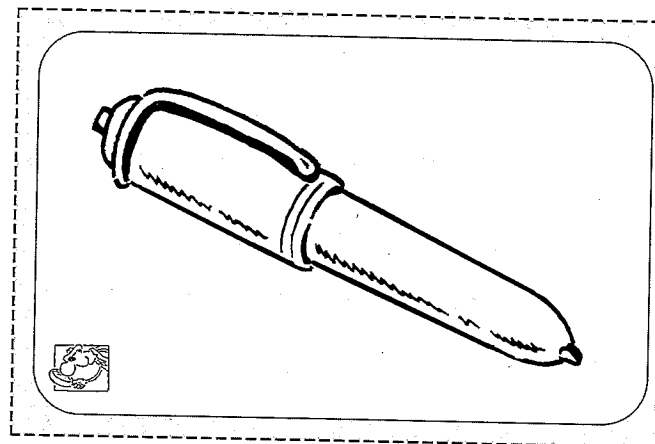
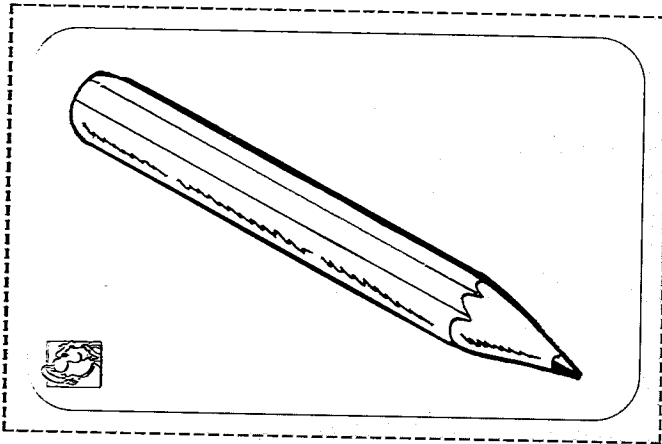

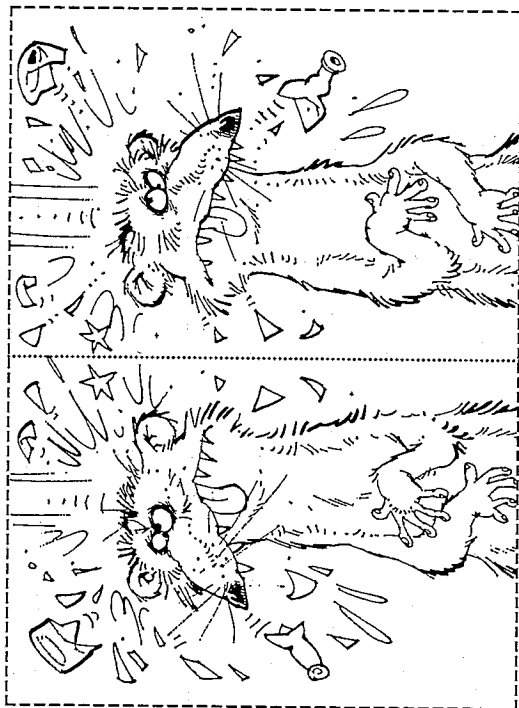
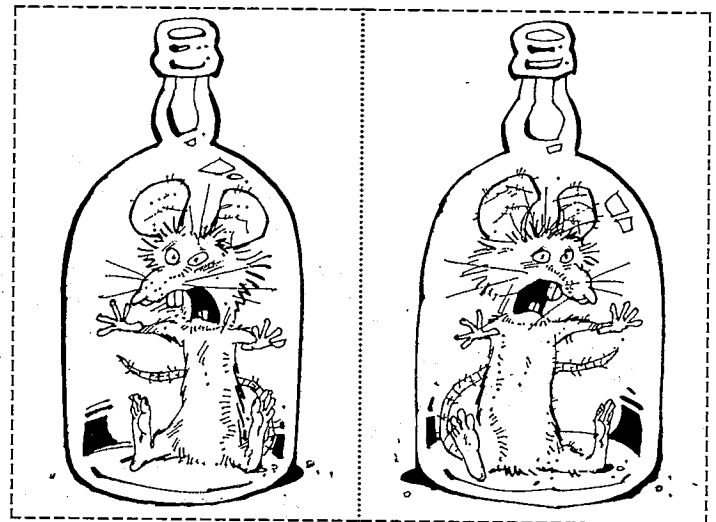
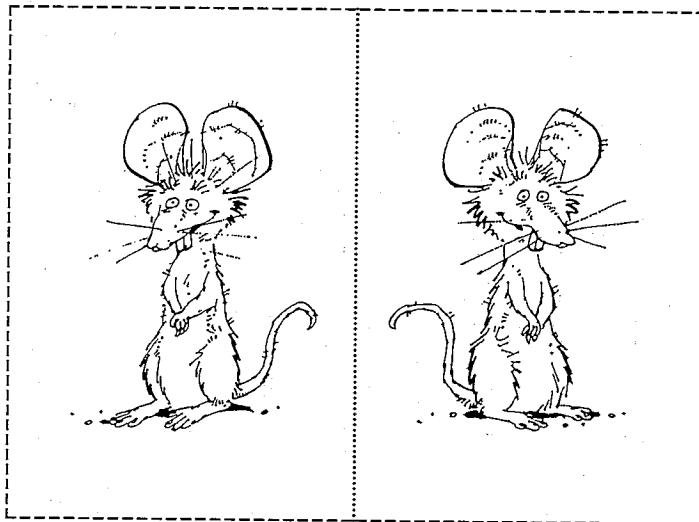
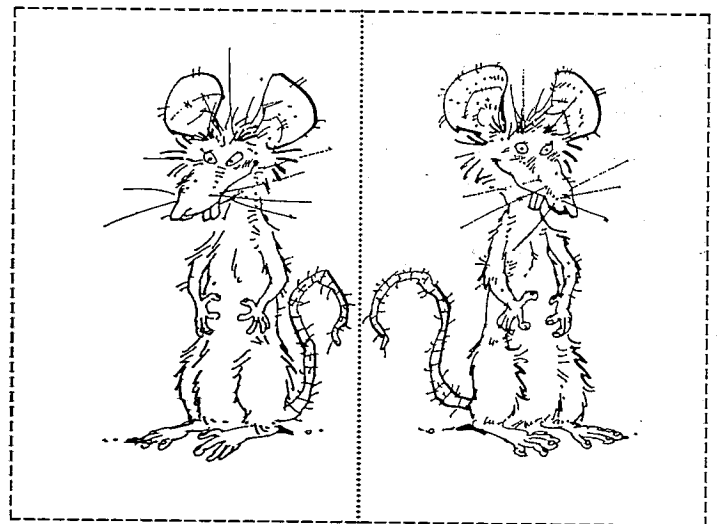
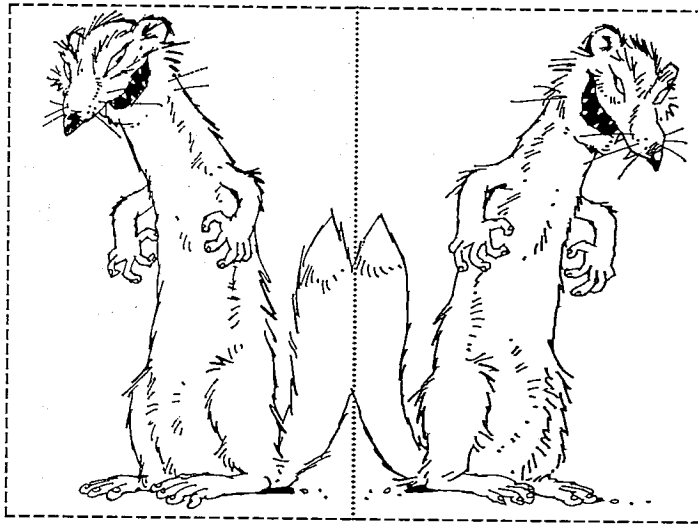

You need:

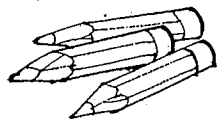

coloured pencils

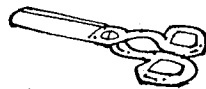

scissors

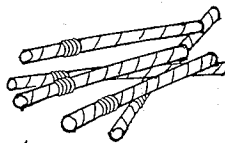

straws



sticky tape

1 Colour.

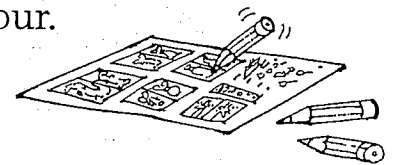

2 Cut.



3 Fold.

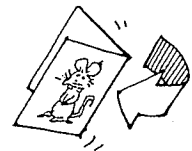

4 Stick.

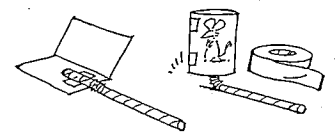

5 Act.



----- cut ----- fold

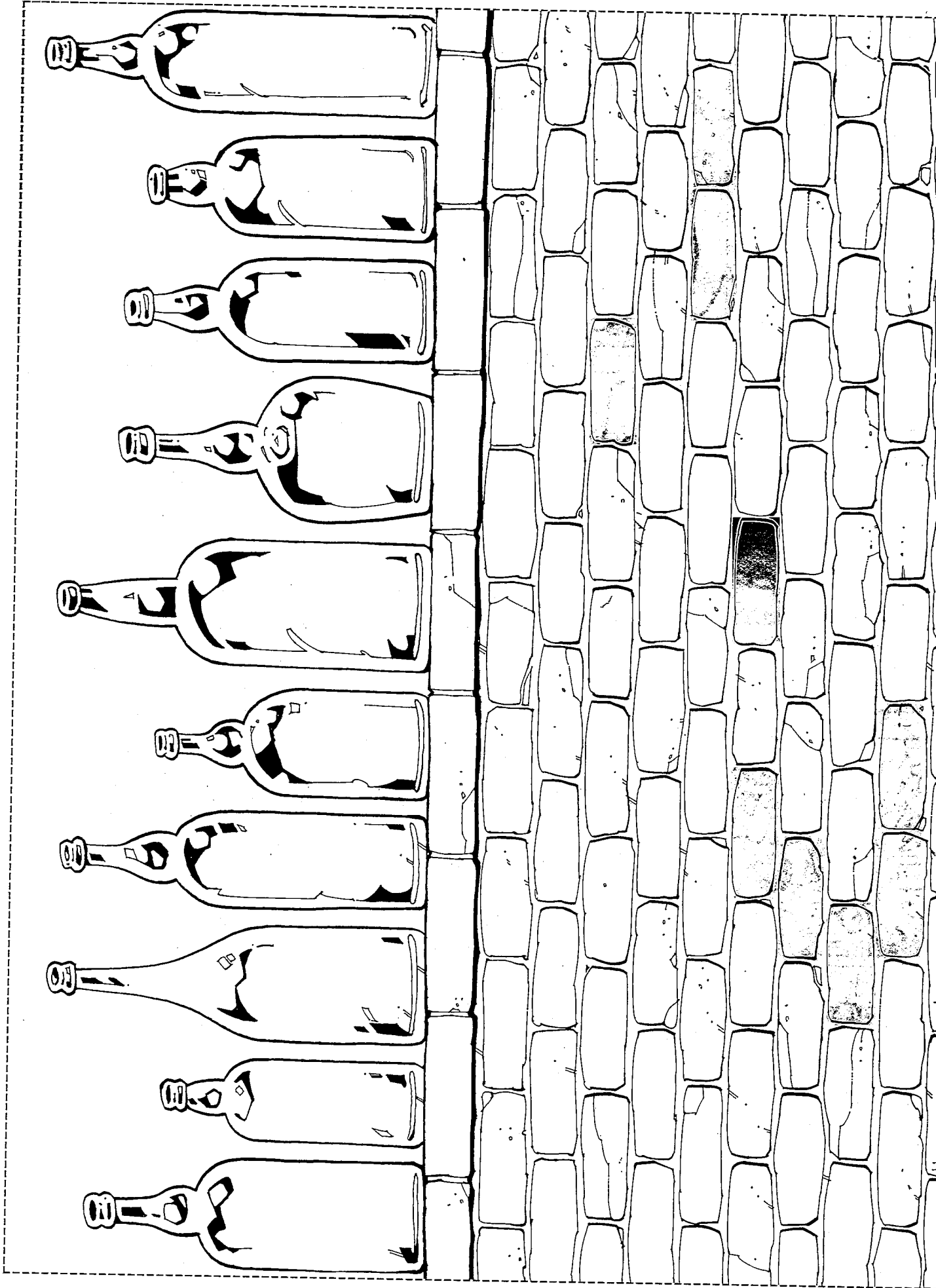

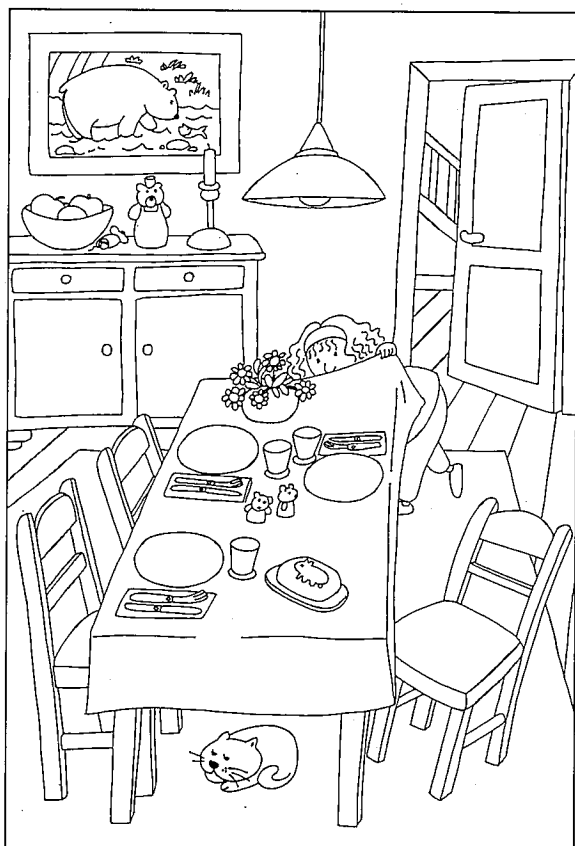
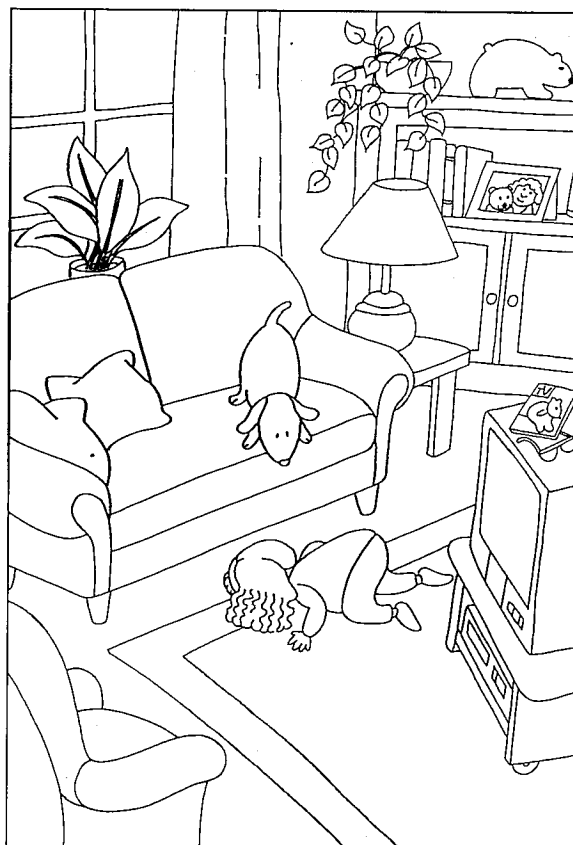
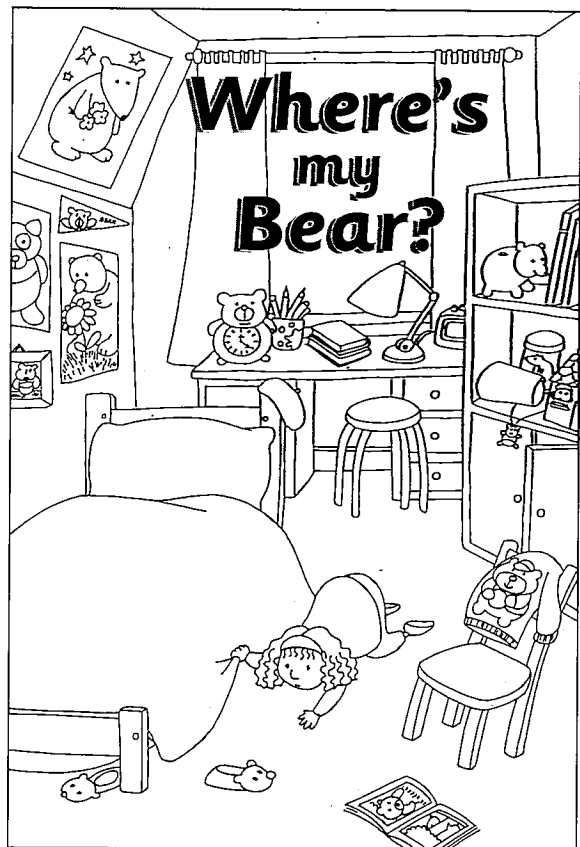

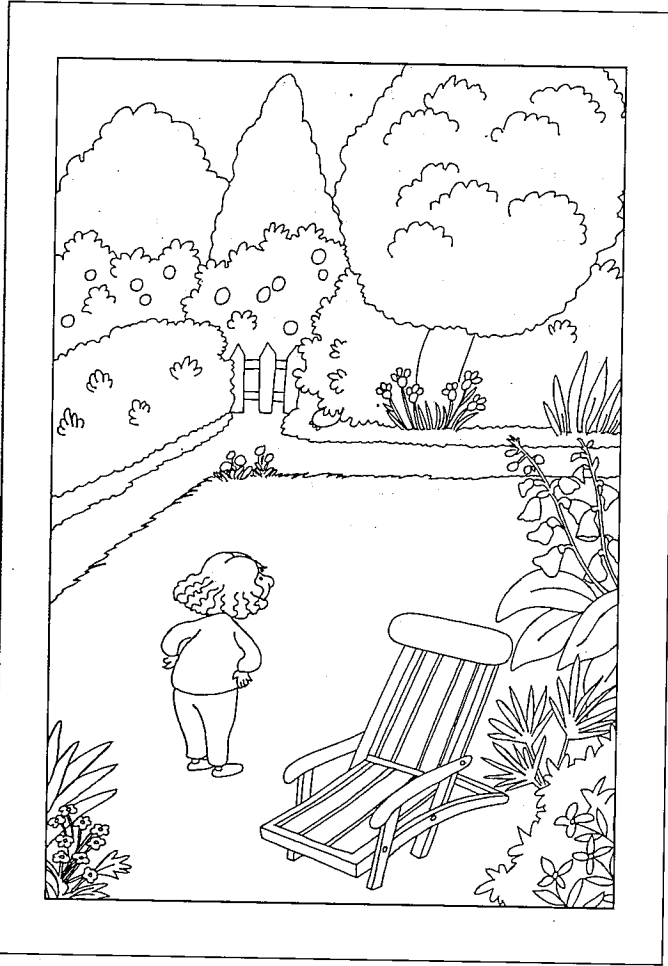
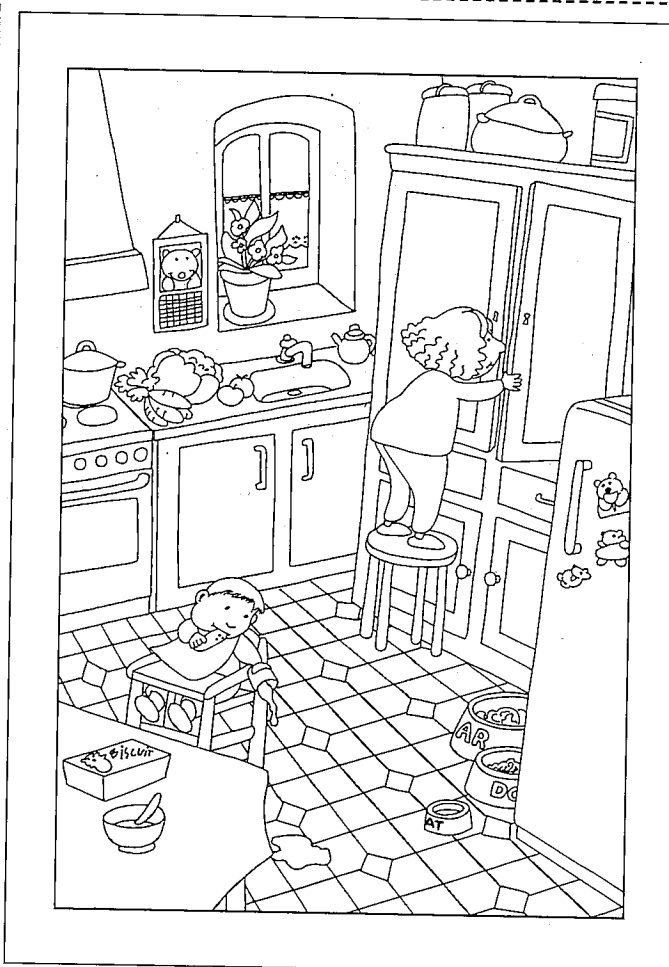





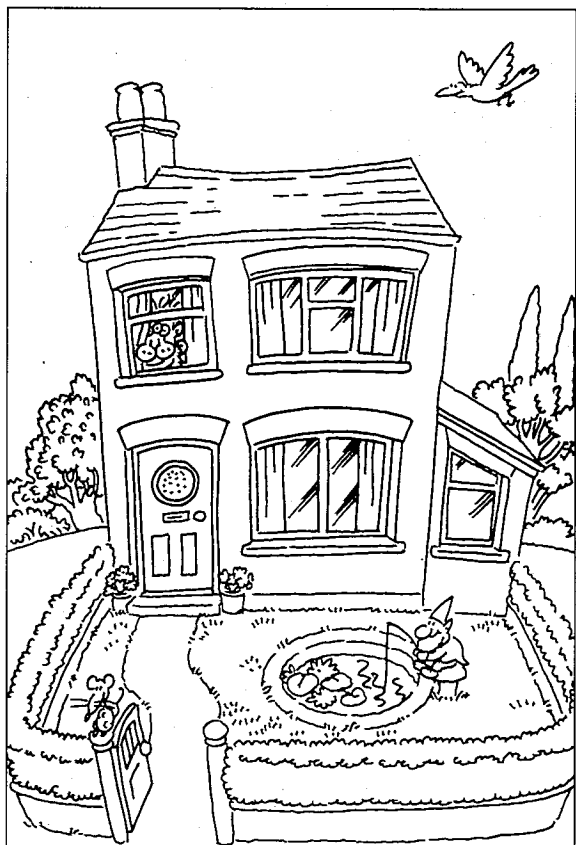
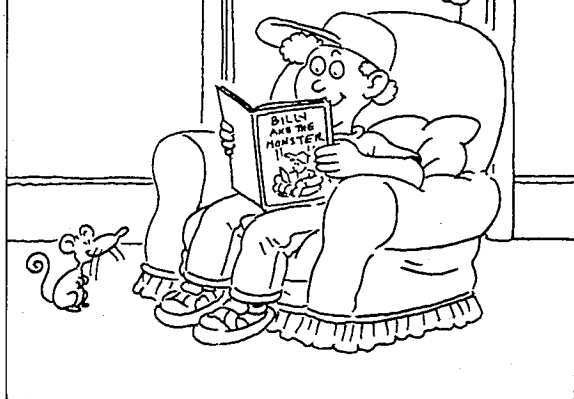

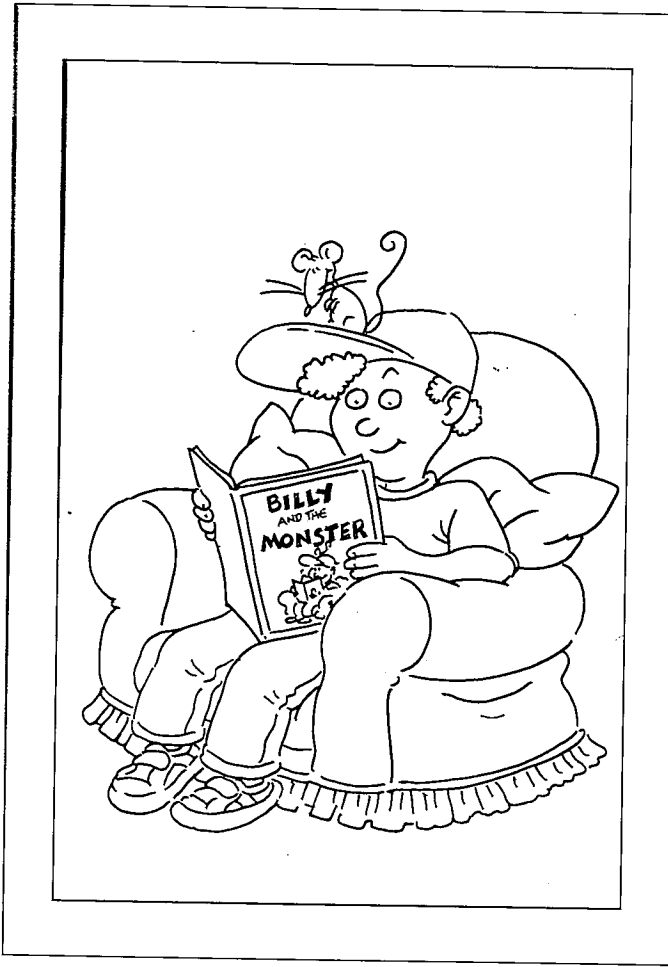

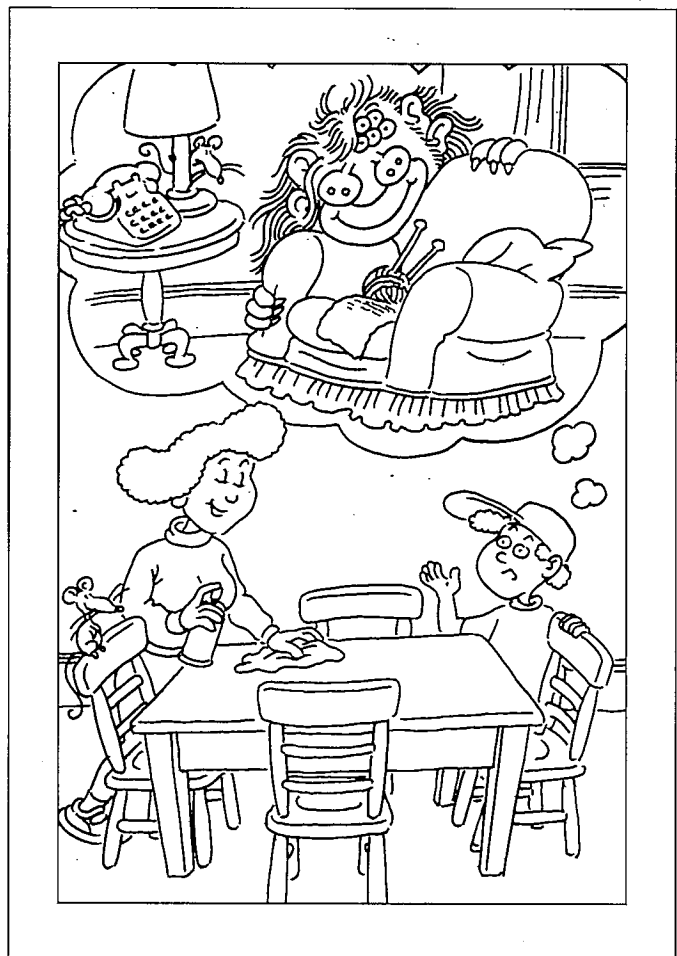

BILLY AND THE MONSTER









<p>Hair brown</p> <p>Eyes green</p> <p>Favourite food pears</p> <p>Favourite colour orange</p> <p>Pet cat</p> <p>001</p> 	<p>Hair black</p> <p>Eyes blue</p> <p>Favourite food apples</p> <p>Favourite colour purple</p> <p>Pet dog</p> <p>002</p> 	<p>Hair blond</p> <p>Eyes brown</p> <p>Favourite food cheese</p> <p>Favourite colour yellow</p> <p>Pet cat</p> <p>003</p> 	<p>Hair grey</p> <p>Eyes green</p> <p>Favourite food eggs</p> <p>Favourite colour pink</p> <p>Pet dog</p> <p>004</p> 
<p>Hair brown</p> <p>Eyes blue</p> <p>Favourite food chips</p> <p>Favourite colour white</p> <p>Pet cat</p> <p>005</p> 	<p>Hair black</p> <p>Eyes brown</p> <p>Favourite food oranges</p> <p>Favourite colour purple</p> <p>Pet dog</p> <p>006</p> 	<p>Hair blond</p> <p>Eyes blue</p> <p>Favourite food chips</p> <p>Favourite colour pink</p> <p>Pet cat</p> <p>007</p> 	<p>Hair grey</p> <p>Eyes brown</p> <p>Favourite food apples</p> <p>Favourite colour purple</p> <p>Pet dog</p> <p>008</p> 

Names								
Questions								
What colour's your hair?								
What colour are your eyes?								
What's your favourite food?								
What's your favourite colour?								
Have you got a pet?								
Spy								



You need:

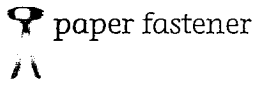
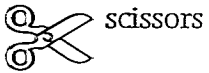

1 Cut out circles A and B.

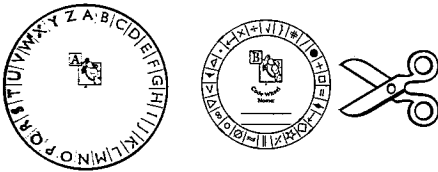

2 Put circle B on circle A. Fix together.

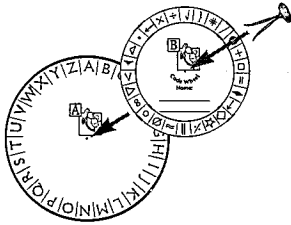

Find the Code Words on the Puzzle Cards.

OPTIONAL

Now cut out circle C. Write your own code and code words.

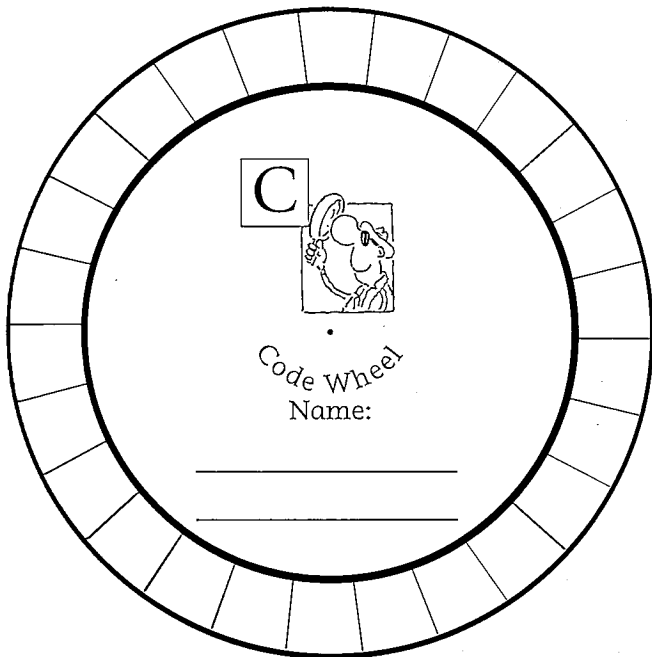
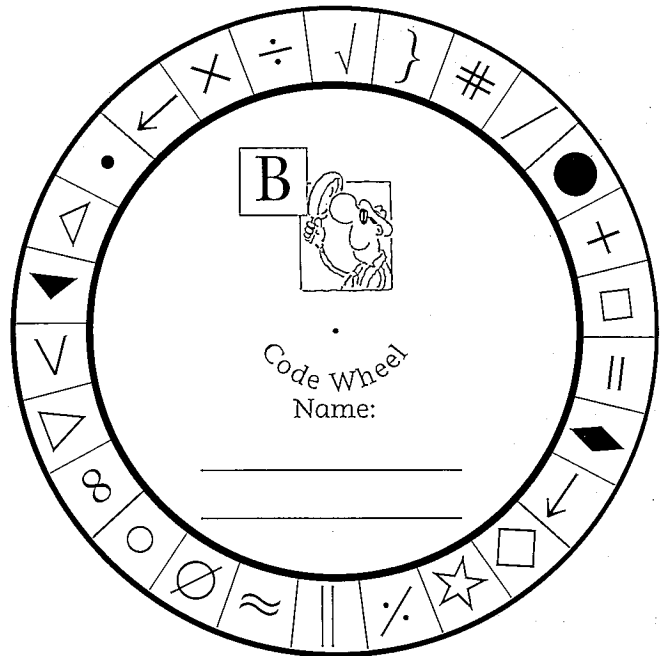
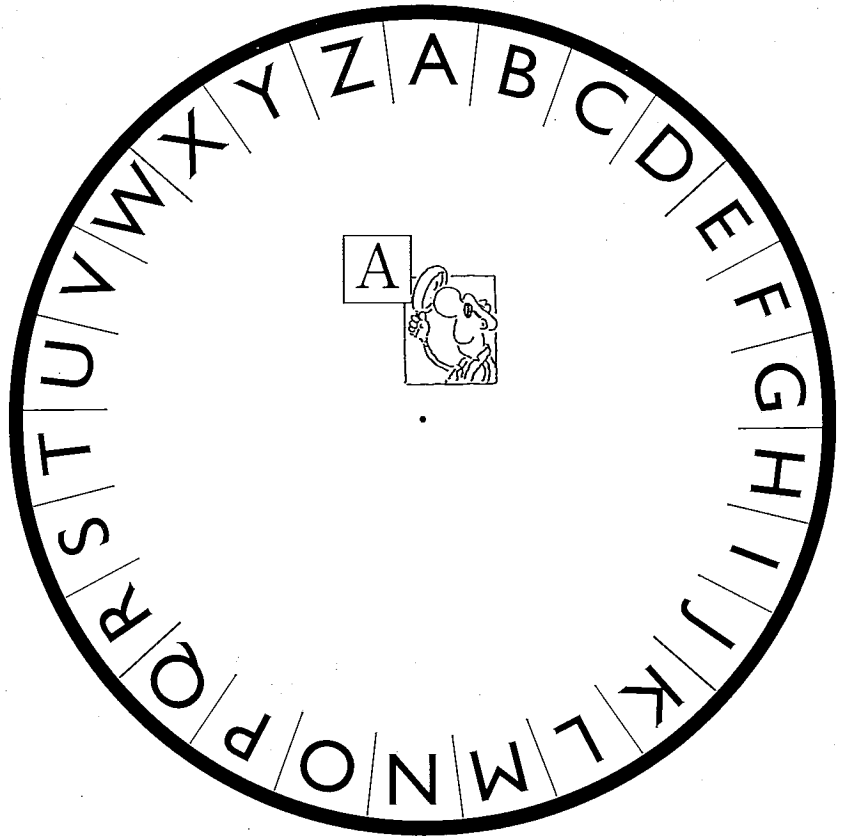



Code Words



1 $\sqrt{\quad}$ $\#$ $\sqrt{\quad}$ ∞

2 \square ∞ \bullet \bullet \parallel

3 $\sqrt{\quad}$ \square \blacklozenge ∞ \star

4 $<$ \bullet \approx

5 \emptyset \blacktriangleleft ∞ \emptyset \star \bullet

6 $+$ \blacklozenge \triangle \bullet

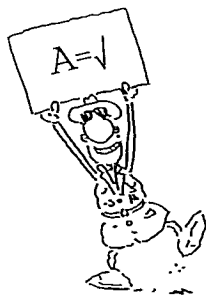

Code Words



1 \bullet \leftarrow $\#$ \div

2 $/$ $\#$ $<$

3 \emptyset \bullet $/$ \rightarrow $=$ $<$

4 \emptyset \circ $<$ ∇

5 $<$ \leftarrow \triangle \bullet \blacklozenge

6 \square $<$ ∇

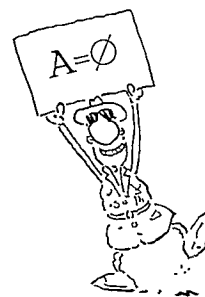

Code Words



1 $/$ \rightarrow \emptyset \div

2 $<$ \div \square \square \rightarrow ∞

3 \blacklozenge $/$ \blacklozenge \div

4 \triangle \bullet \rightarrow $<$

5 \parallel $/$ ∇

6 \triangle \leftarrow \triangle \approx

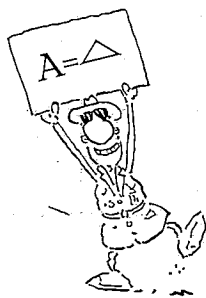

Code Words



1 \parallel \leftarrow \square \circ

2 $+$ $<$ $/$ \circ \circ

3 \div \emptyset $\sqrt{\quad}$ ∇

4 $\sqrt{\quad}$ $/$ \div \div ∇ \circ

5 \blacklozenge $<$ \blacktriangleleft $+$ \circ

6 \bullet \circ $=$ \circ \div

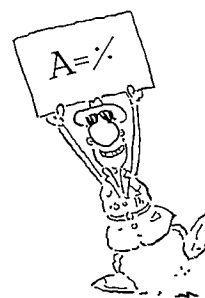



Code Words



1 $\blacklozenge \rightarrow \cdot \cdot \blacktriangledown$

2 $\blacklozenge \leftarrow \div \triangle \blacklozenge \circ <$

3 $\blacklozenge \} \div \div \div$

4 $\blacklozenge \rightarrow \blacklozenge \approx$

5 $\blacklozenge \blacktriangledown \circ \} \div$

6 $\div \circ \approx \emptyset \}$

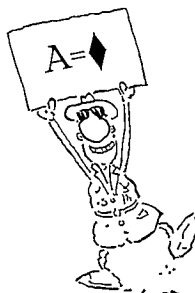

Code Words



1 $\bullet \blacktriangledown \emptyset / + \times$

2 $\star \# + \div \div \emptyset \#$

3 $\star \bullet \star \div \cdot \emptyset$

4 $\div \times \emptyset$

5 $\star \sqrt{\quad} \emptyset \times$

6 $\star \div < \times$



Code Words



1 $= \blacktriangledown \}$

2 $= \triangle \blacktriangledown < \div \# \# +$

3 $\approx \emptyset \# = = \div \blacktriangledown$

4 $\approx \emptyset \approx \div \div$

5 $\approx \infty \# \# +$

6 $\blacklozenge \triangle \cdot = \blacktriangledown$



Code Words



1 $\# \times \# \parallel \parallel$

2 $\# \infty \square \emptyset \bullet \blacklozenge \parallel$

$\blacktriangleleft \rightarrow \# < \infty \square \emptyset \square <$

3 $\triangle \rightarrow \square \approx \circ \circ \emptyset$

4 $\# \bullet \rightarrow \# \blacklozenge <$

5 $\# < \cdot \parallel \square <$

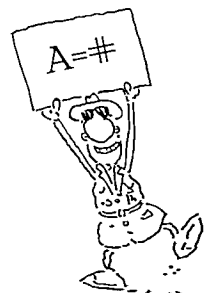



Code Words



1 $\triangle \# \triangle \div \triangle \bullet$

2 $\infty < \infty \bullet \blacktriangleleft \# \triangle$

3 $\infty \rightarrow \bullet \infty \} \triangle$

4 $\infty \blacklozenge \star \nabla \nabla \triangle \blacklozenge$

5 $+ \blacklozenge \infty \bullet \leftarrow \triangle$

6 $\infty \emptyset + \emptyset +$

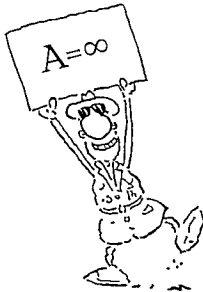

Code Words



1 $\diamond \sqrt{} \leftarrow + \bullet$

2 $\rightarrow \star \circ \rightarrow \infty \sqrt{}$

3 $\rightarrow \diamond \infty \sqrt{} \# \circ \div \rightarrow =$

$\star \rightarrow < \parallel$

4 $\rightarrow \diamond \rightarrow \blacktriangleleft \blacktriangleleft$

5 $\diamond \blacktriangleleft / \parallel$

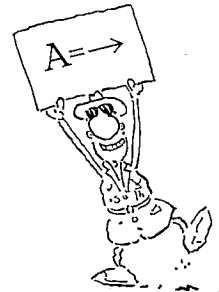

Code Words



1 $/ \square \infty \infty \blacktriangleleft$

2 $\blacklozenge \infty \leftarrow \blacktriangleleft$

3 $/ \blacklozenge \approx \infty \div = \blacktriangleleft$

4 $/ \bullet / \approx \approx \infty \infty \circ$

5 $\rightarrow \blacktriangleleft = \}$

6 $\bullet \div = \approx \times =$

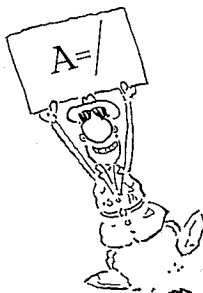

Code Words



1 $\times \parallel \# \times \emptyset$

2 $\times \parallel \emptyset \# \circ \# \star \infty$

3 $\div \rightarrow \times \sqrt{} \blacklozenge$

4 $\times \blacklozenge \square \infty \#$

5 $\star \square \star \#$

6 $\times \div \times \div \bullet$

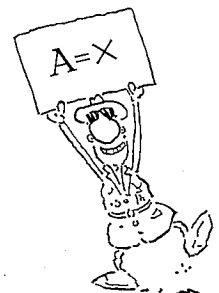



A B C D E F G H I J K L M N O P Q R S T U V W X Y Z

Code Strip A

Name _____

Stick strip B here.

A B C D E F G H I J K L M N O P Q R S T U V W X Y Z

Code Strip B

1 2 3 4 5 6 7 8 9 10 11 12 13 14 15 16 17 18 19 20 21 22 23 24 25 26

Code Strip C

Name _____

Code Strip D

Name _____

You need:



scissors



glue

1 Cut out strips A and B.

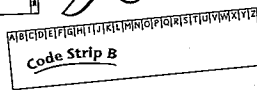
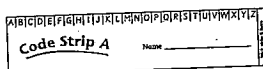

2 Stick.

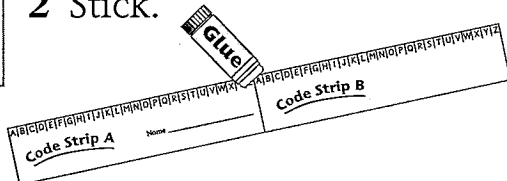

3 Cut out strip C. Find the Code Words on the Puzzle Cards.

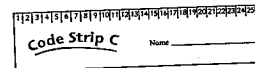

OPTIONAL

Cut out strip D. Write your own code and code words.

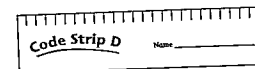



Code Words

1
A=10

1 10, 21, 18, 24, 23

2 10, 23, 14, 16, 16

3 21, 18, 5, 18, 23, 16, 1, 24, 24, 22

4 10, 25, 18, 16

5 11, 10, 3, 17, 1, 24, 24, 22

6 10, 17, 24, 1, 2, 14



Code Words

2
A=5

1 5, 6, 9, 9

2 15, 13, 24, 7, 12, 9, 18

3 5, 18, 9, 16, 9, 20, 12, 5, 18, 24

4 5, 18, 25, 17, 6, 22, 9, 16, 16, 5

5 5, 23, 12, 9, 9, 20

6 6, 9, 8, 22, 19, 19, 17



Code Words

3
A=21

1 21, 23, 9, 17

2 21, 2, 21, 14

3 21, 22, 3, 12, 24

4 21, 8, 3, 23, 25, 23, 12, 25, 21, 7

5 21, 14, 9, 3, 6, 25, 14

6 21, 8, 9, 12, 21, 8, 1, 25



Code Words

4
A=16

1 16, 21, 7, 4, 22

2 19, 24, 3, 24, 3, 22, 7, 4, 4, 2

3 16, 3, 16, 5, 5, 1, 20

4 16, 7, 16, 17, 17, 24, 9

5 16, 18, 1, 4, 18, 26

6 16, 26, 20, 14





Code Words

A B C D E F G H I J K L

5

A=25

- 1 1, 6, 7, 14, 17
— — — — —
- 2 25, 26, 7, 9, 3
— — — — —
- 3 25, 26, 25, 12, 25, 12, 25
— — — — —
- 4 25, 26, 25, 26, 23
— — — — —
- 5 25, 4, 10, 25, 5
— — — — —
- 6 25, 26, 3, 25, 16
— — — — —



Code Words

A B C D E F G H I J K L

6

A=13

- 1 13, 12, 21, 2
— — — — —
- 2 13, 6, 1, 25, 13, 6, 1
— — — — —
- 3 13, 19, 20, 1, 5, 6
— — — — —
- 4 15, 20, 1, 15, 1, 24, 13, 6, 17
— — — — —
- 5 13, 23, 17, 11
— — — — —
- 6 13, 26, 13, 2, 2, 24, 17
— — — — —



Code Words

A B C D E F G H I J K L

7

A=9

- 1 9, 12, 23, 20, 20
— — — — —
- 2 9, 16, 9, 21, 10, 3, 26, 15, 13, 26
— — — — —
- 3 9, 22, 3, 21, 10, 26, 13, 20, 20, 9
— — — — —
- 4 9, 14, 17, 1, 16
— — — — —
- 5 9, 1, 2, 9, 26
— — — — —
- 6 2, 5, 13, 20, 4, 13
— — — — —



Code Words

A B C D E F G H I J K L

8

A=20

- 1 22, 1, 24, 24, 12, 24
— — — — —
- 2 20, 21, 8, 17
— — — — —
- 3 20, 9, 5, 20, 7, 24
— — — — —
- 4 20, 11, 8, 21, 8, 13
— — — — —
- 5 20, 9, 2, 19, 19, 20
— — — — —
- 6 24, 5, 24, 15, 24, 7
— — — — —





Code Words

ABCDEFGHIJKLMN
9
 A=3

1 3, 24, 3, 16

2 3, 15, 17, 23, 22, 10

3 3, 22, 3, 4, 14, 7

4 3, 15, 17, 16, 21, 22, 7, 20

5 5, 10, 11, 18, 21

6 3, 4, 11, 13, 7



Code Words

ABCDEFGHIJKLMN
10
 A=18

1 18, 5, 22, 16, 22

2 18, 8, 12, 22, 22, 5

3 18, 11, 9, 22, 22

4 25, 18, 26, 9

5 16, 22, 3, 3, 6, 14

6 20, 25, 22, 22, 10, 22



Code Words

ABCDEFGHIJKLMN
11
 A=6

1 6, 19, 20, 24, 10

2 11, 14, 1, 10

3 6, 17, 10, 6, 11

4 6, 8, 20, 6, 25

5 6, 12, 13, 20, 24, 25

6 6, 11, 23, 20, 12



Code Words

ABCDEFGHIJKLMN
12
 A=23

1 23, 10, 1, 23, 14

2 23, 19, 23, 16, 25, 4

3 23, 14, 11, 24, 11, 16

4 3, 14, 1, 1, 10

5 23, 4, 11, 14, 15, 1

6 6, 1, 23, 10, 15



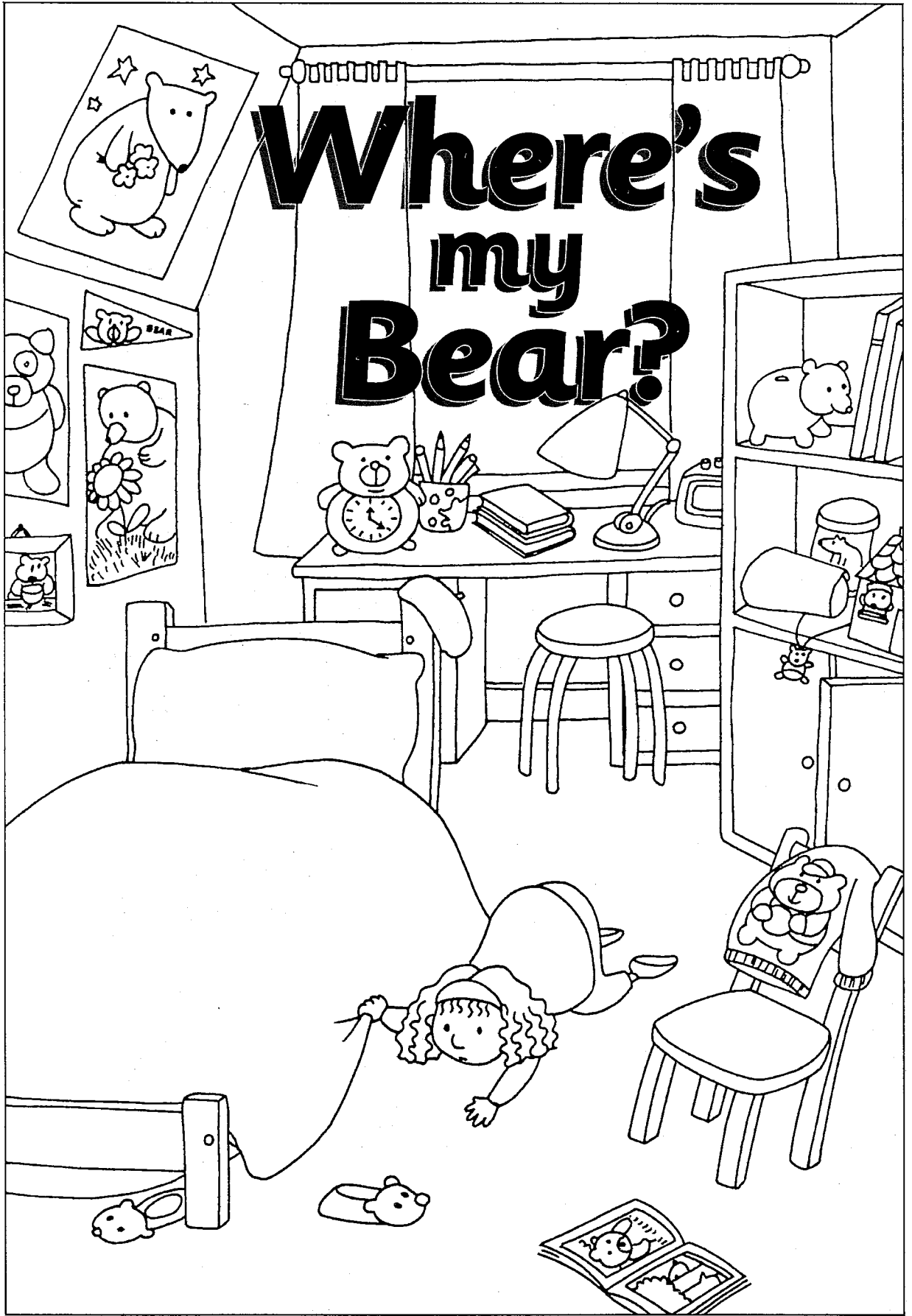

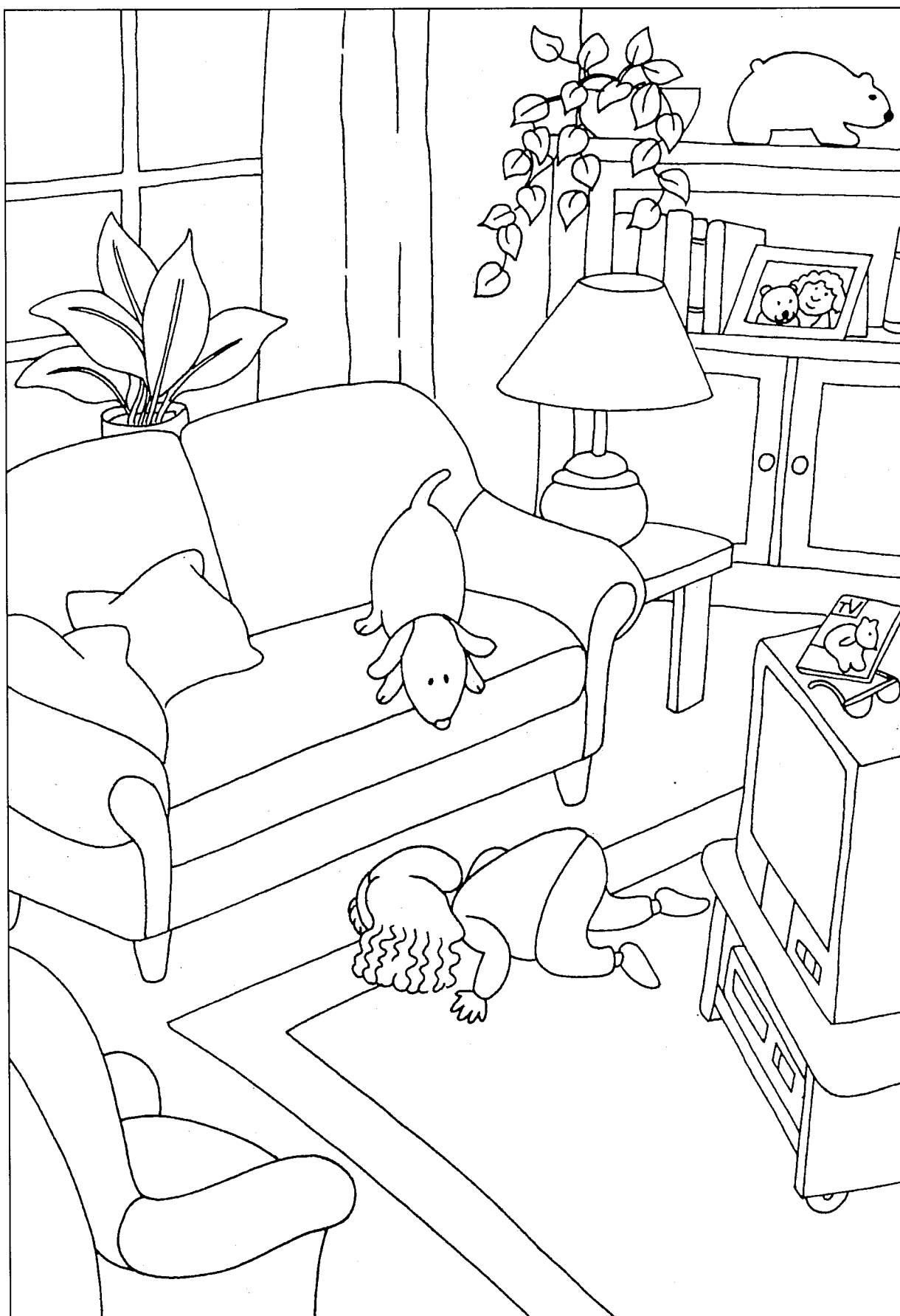



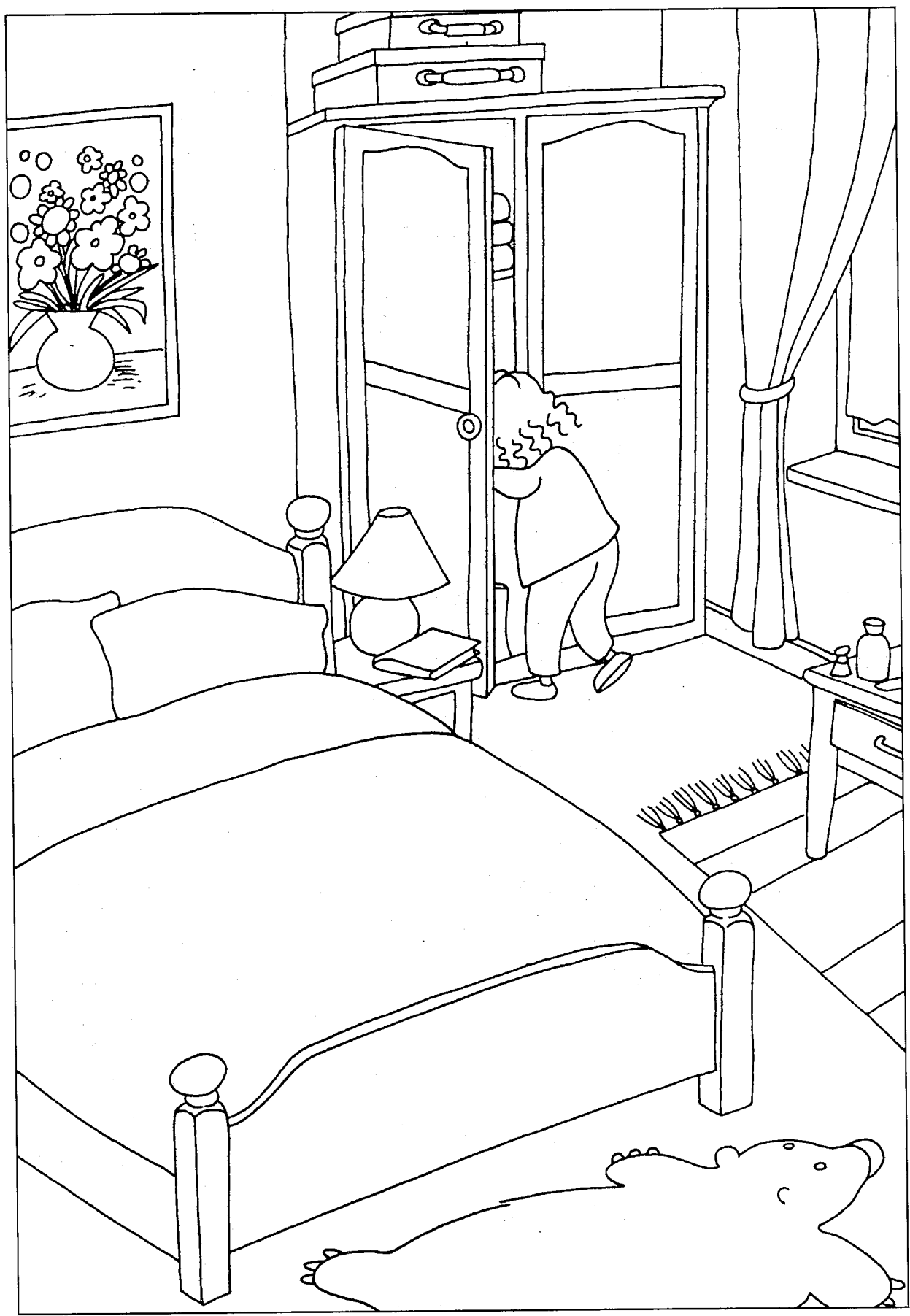

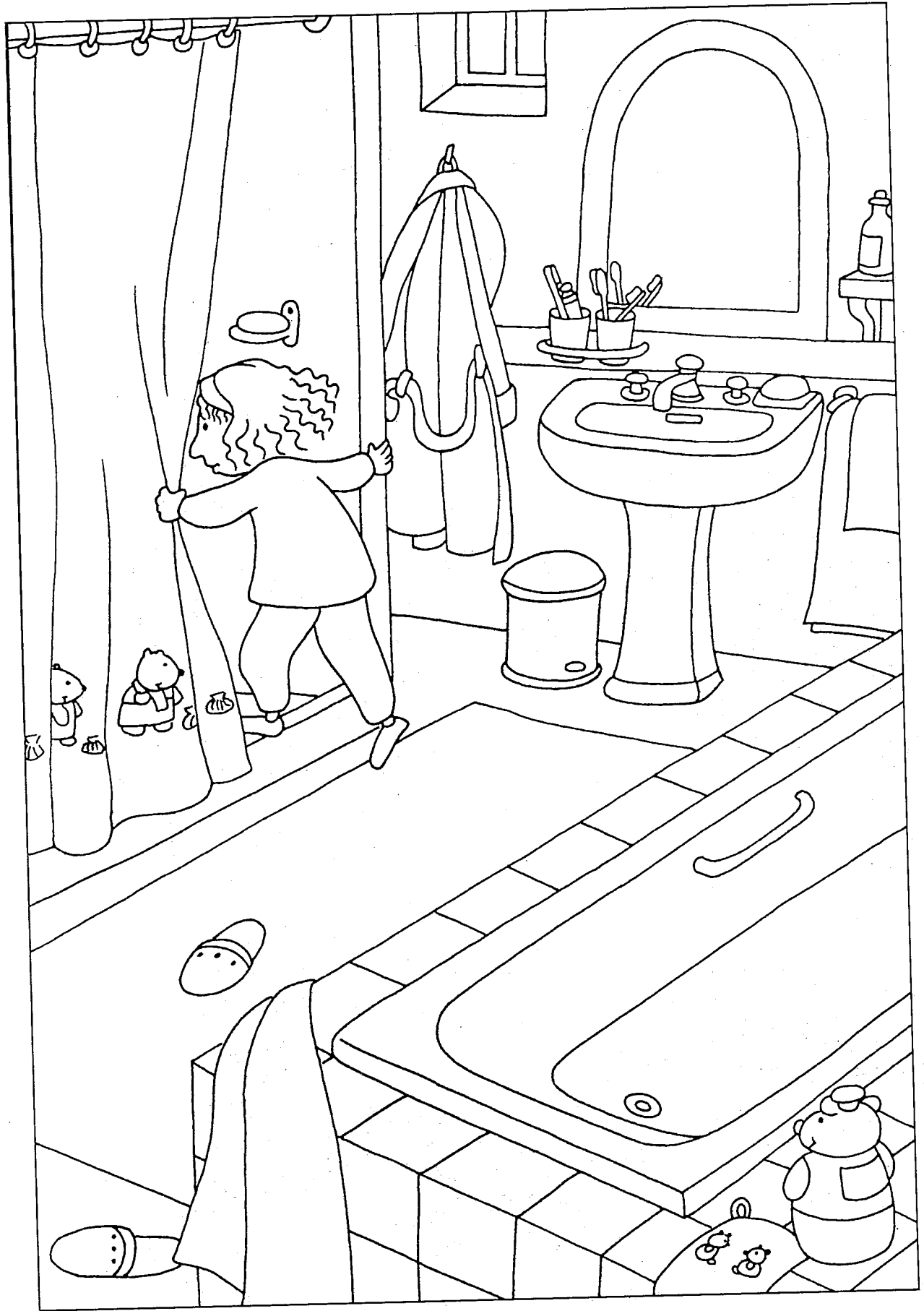



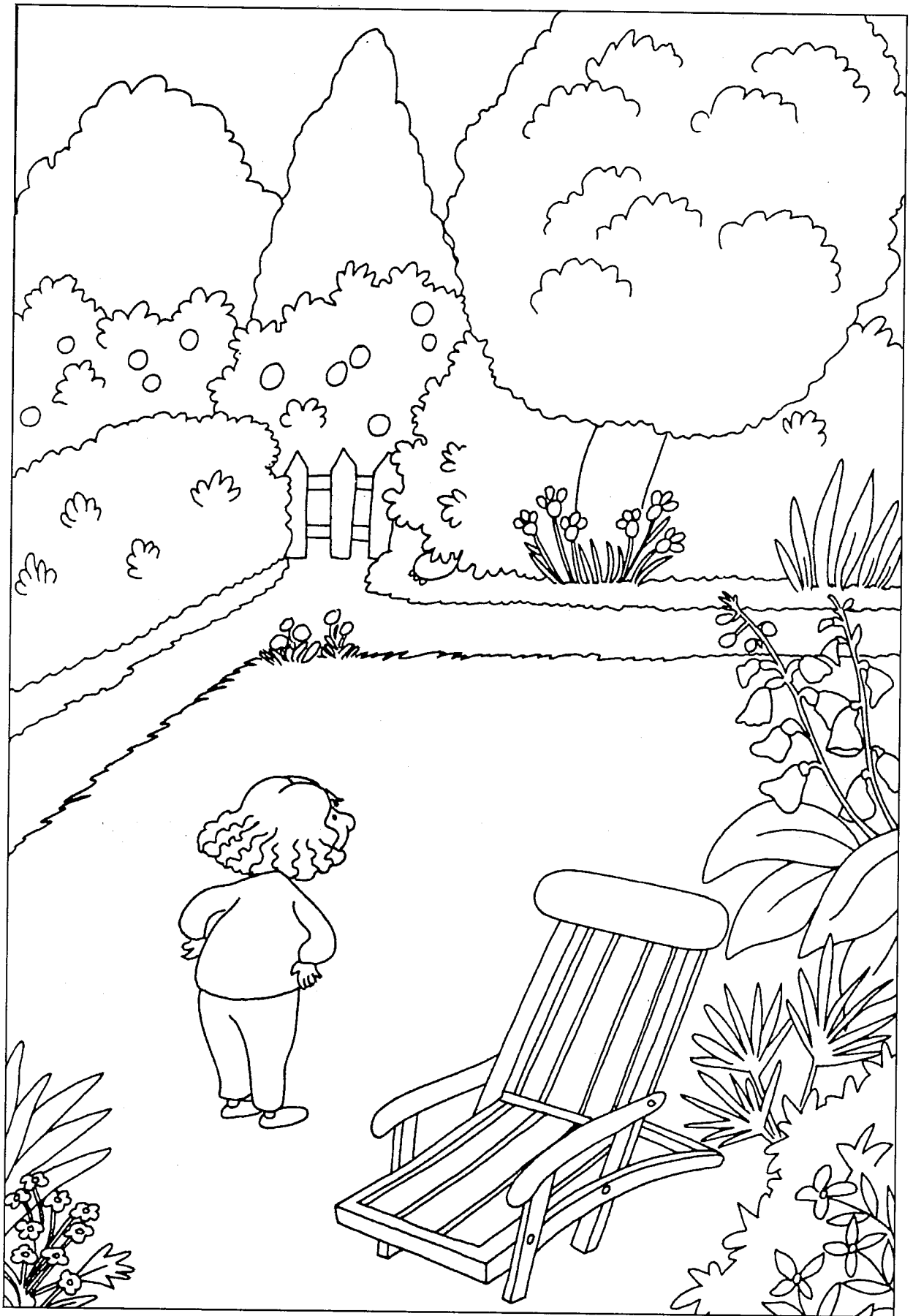



BILLY AND THE MONSTER









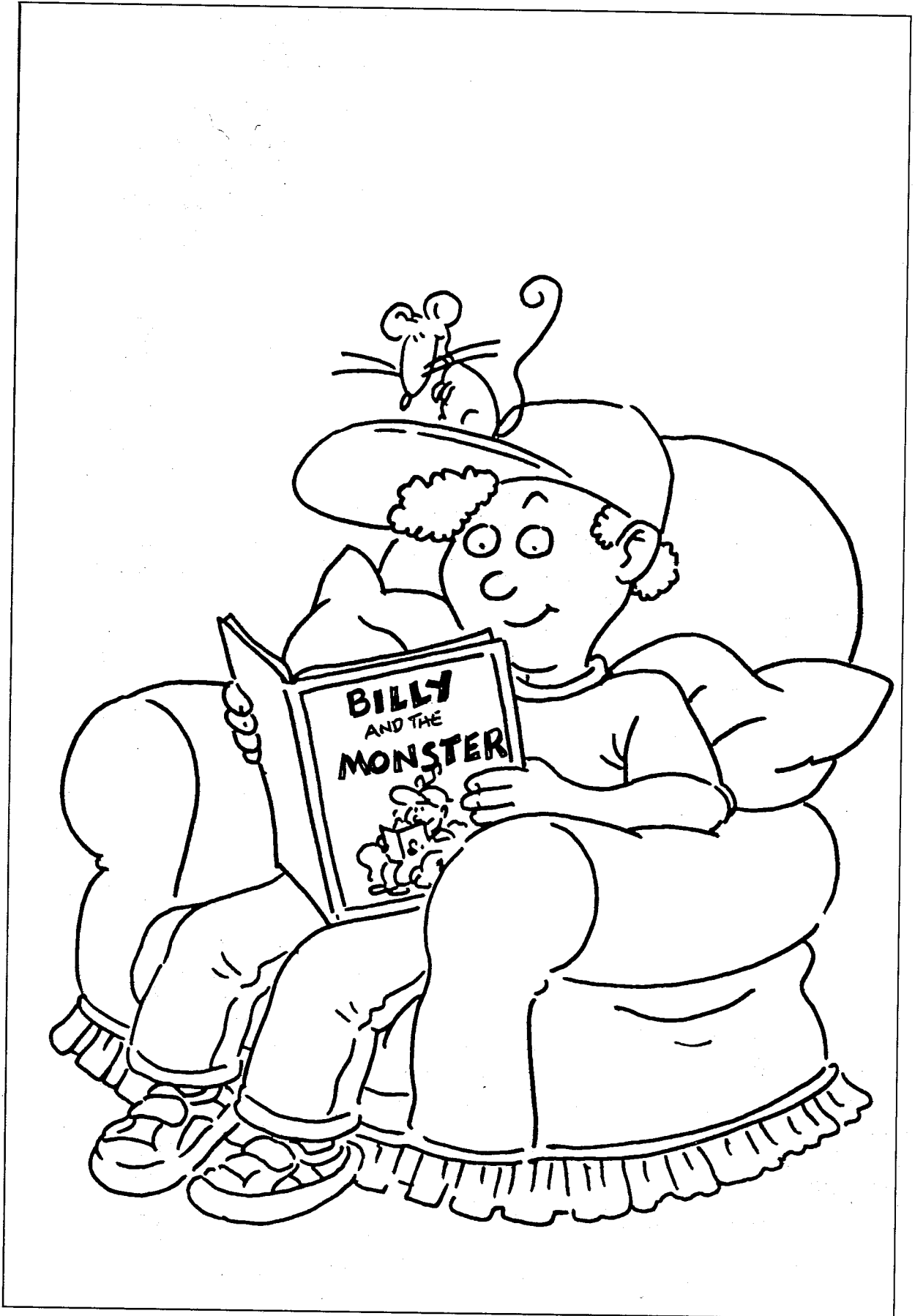

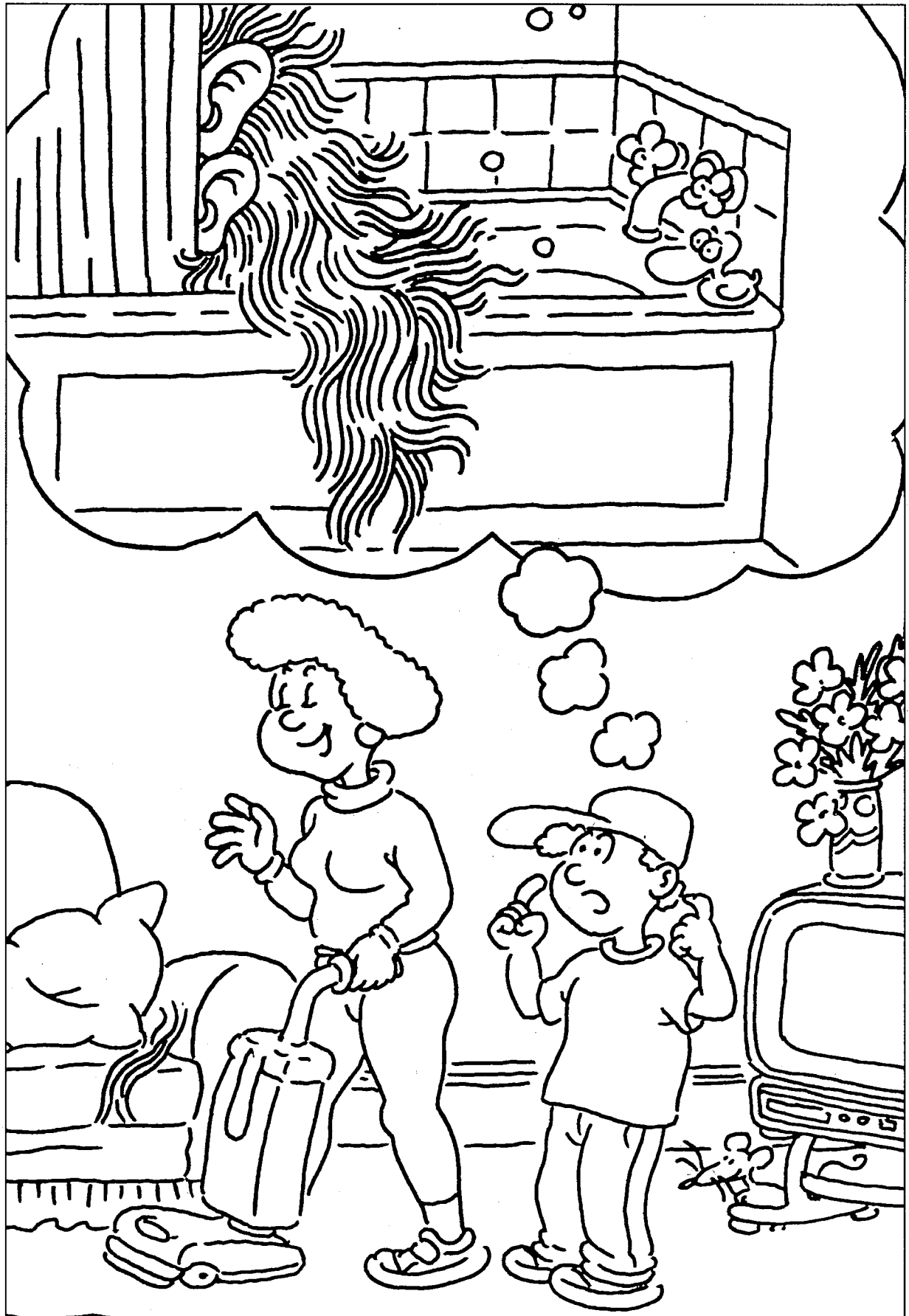

Monster: hair = pink ears = yellow

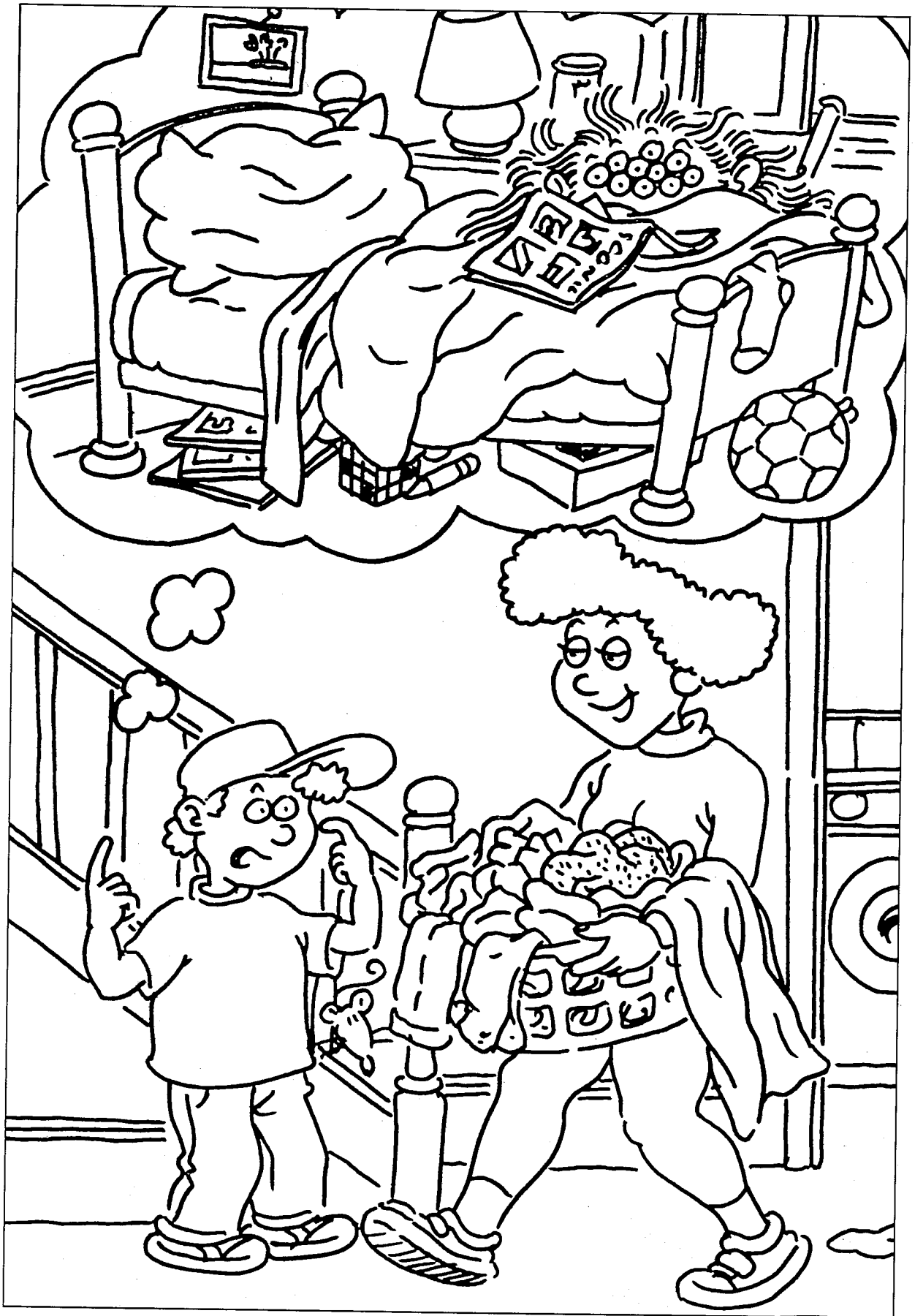

Monster: hair = pink ears = yellow eyes = red

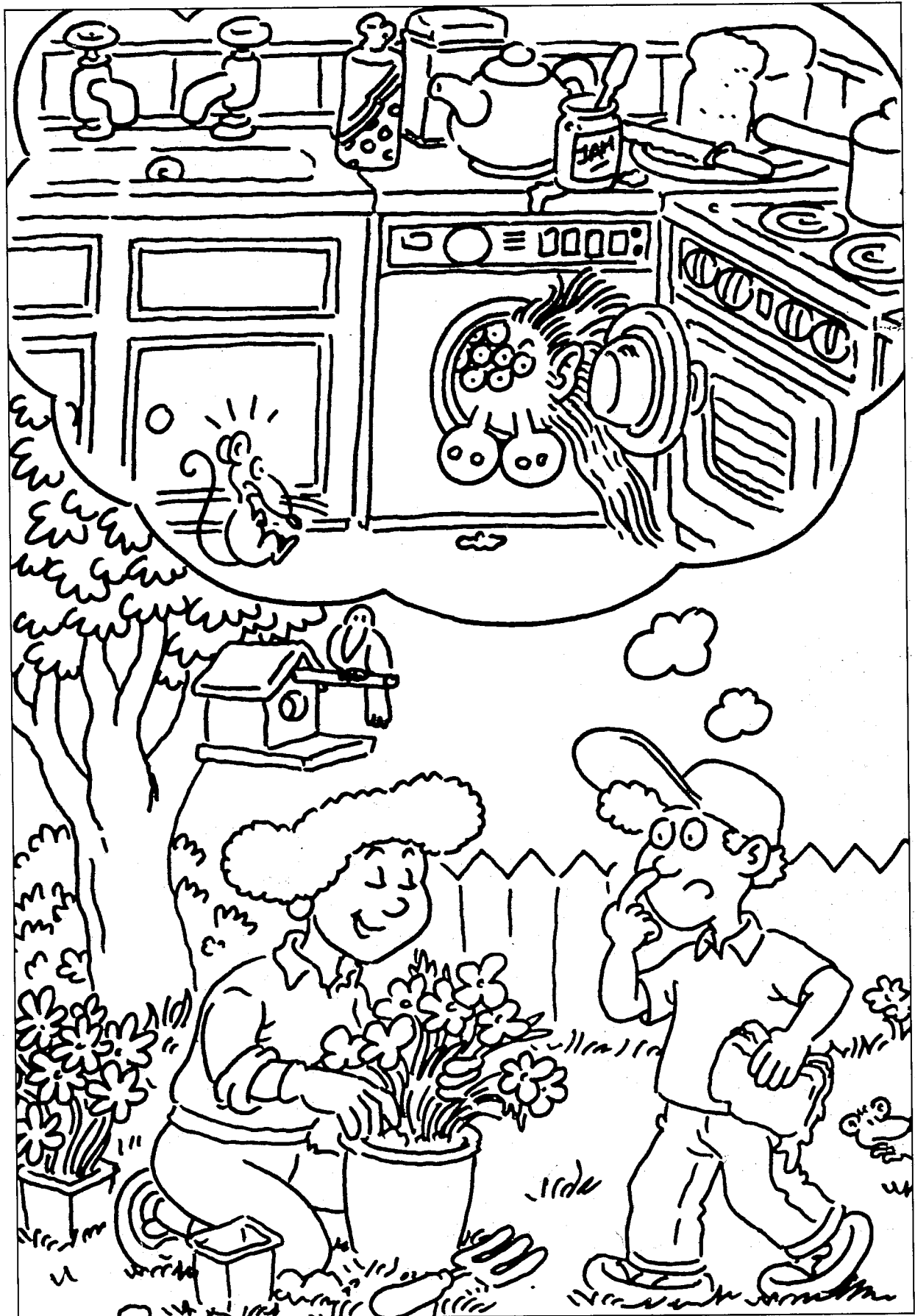

Monster: hair = pink ear = yellow eyes = red noses = purple

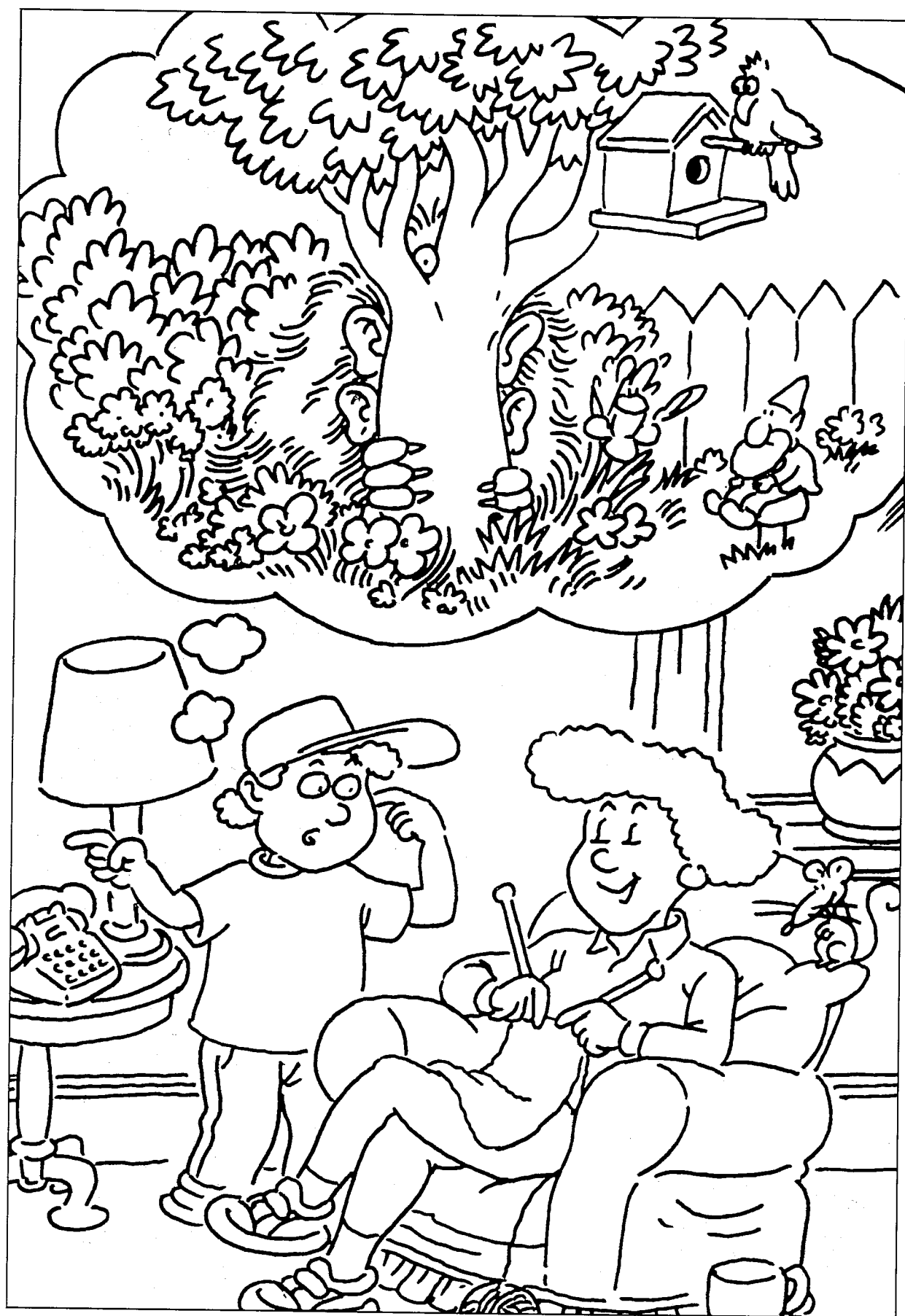

Monster: hair = pink ears = yellow eye = red fingers = yellow

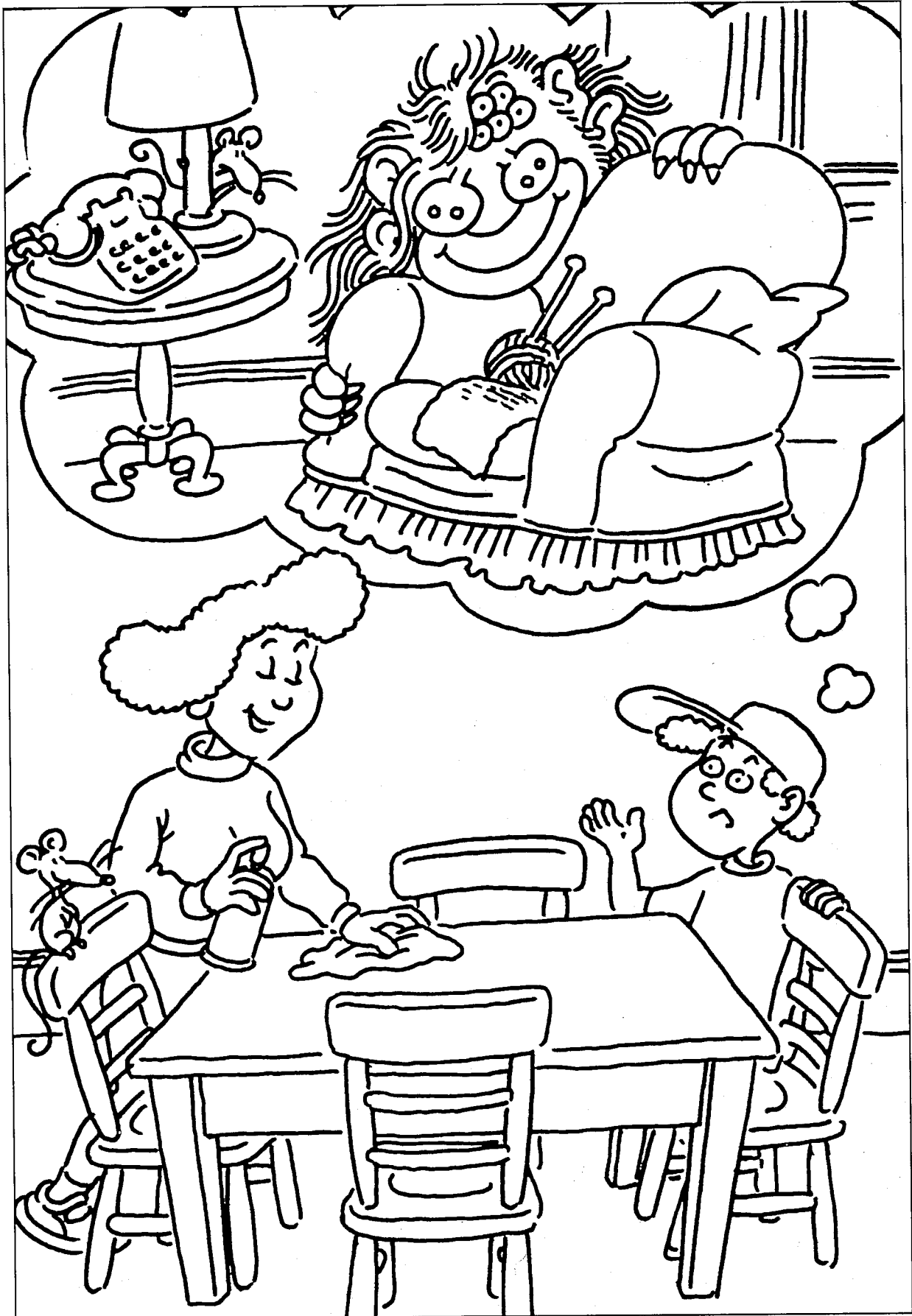

Monster: hair = pink ears = yellow eyes = red noses = purple
fingers = yellow mouth = orange

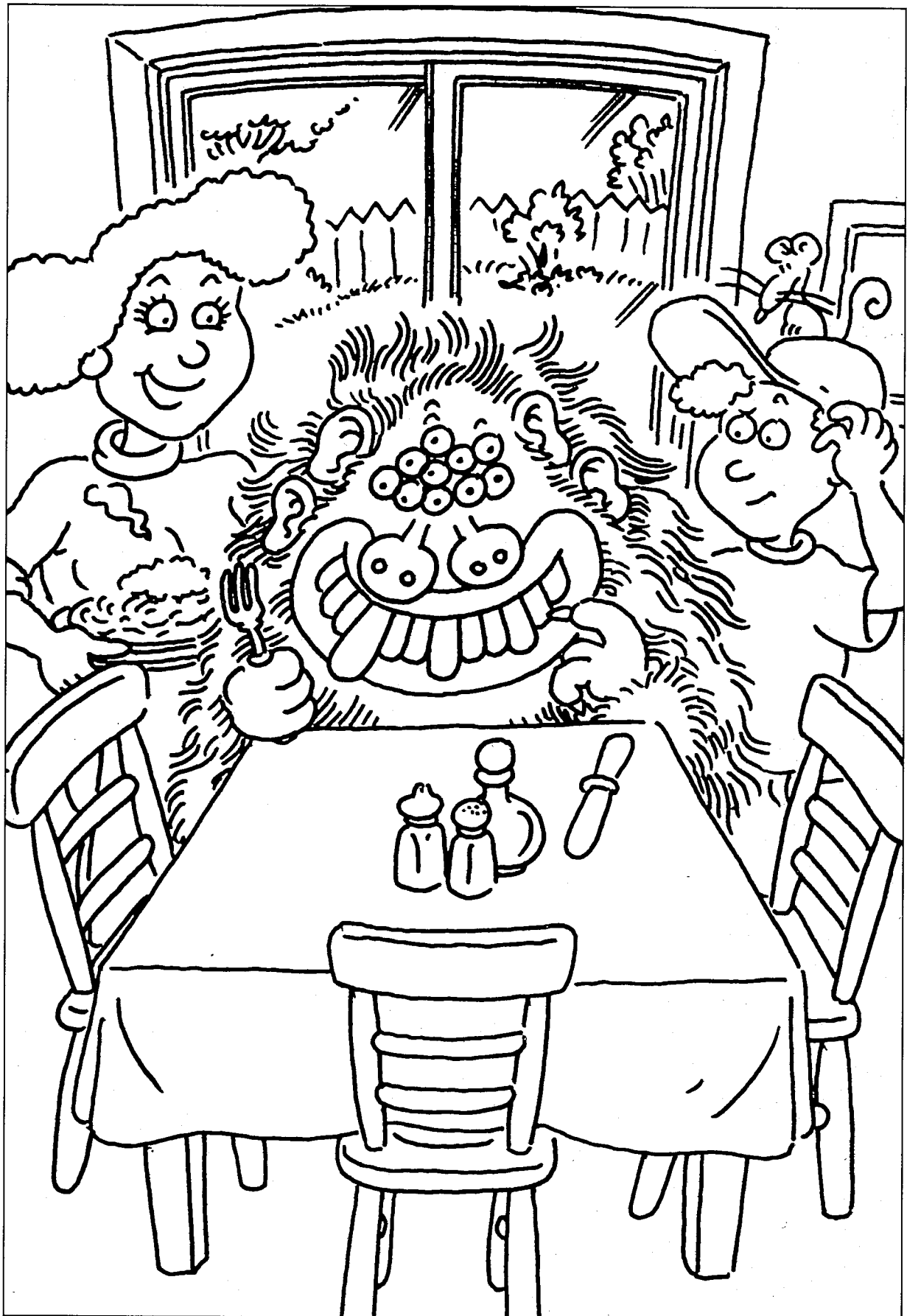

Monster: hair = orange ears = red eyes = orange noses = blue
fingers = purple mouth = yellow teeth = green

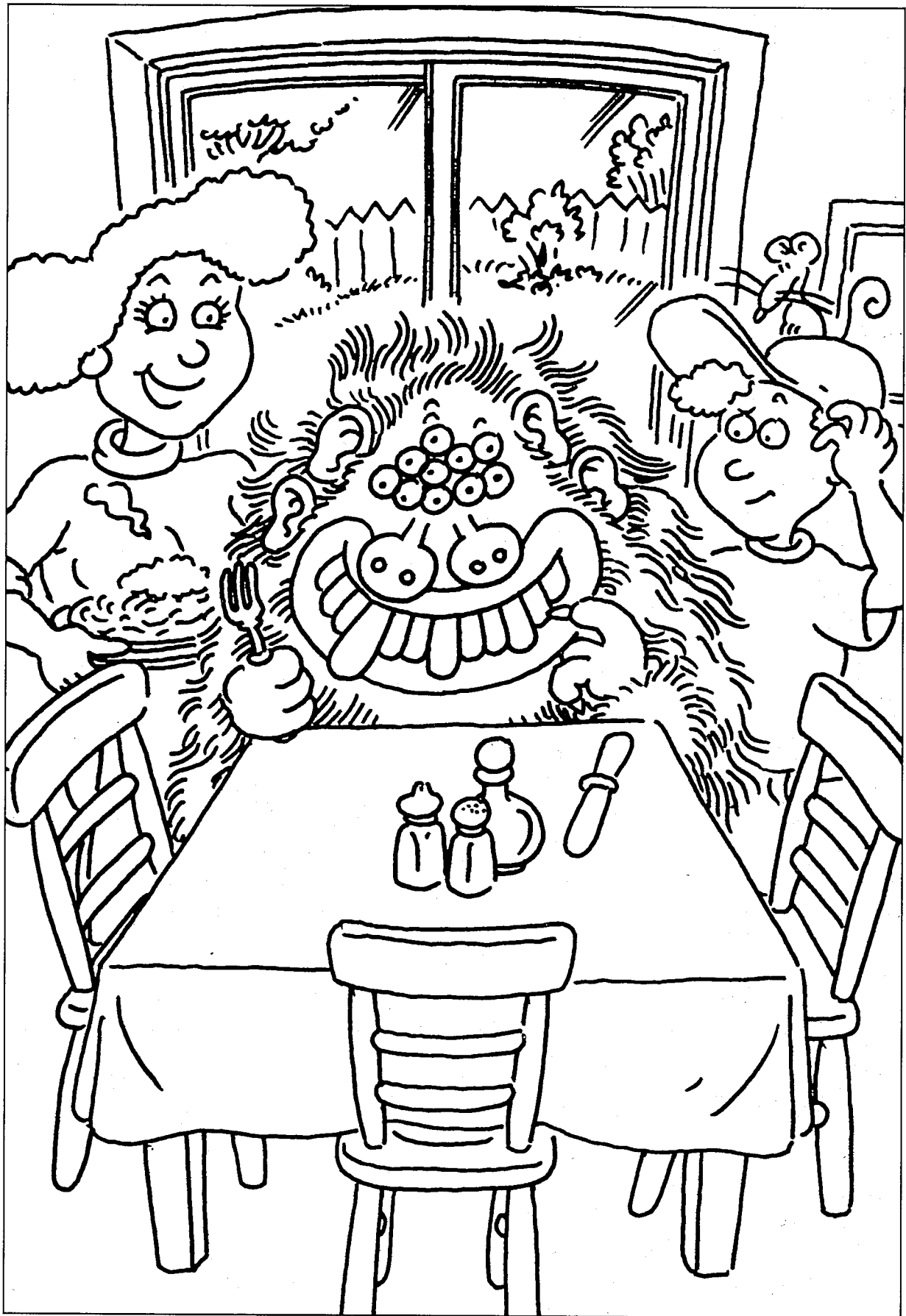

Monster: hair = orange ears = red eyes = orange noses = blue
fingers = purple mouth = yellow teeth = green